



# ALAM Journal of Maritime Studies

Volume 4, Issue 1, 2023

ISSN No: 2590-4345

# **ALAM Journal of Maritime Studies**

ALAM Journal of Maritime Studies (AJMS) is a peer – reviewed journal published annually by Akademi Laut Malaysia (ALAM). We welcome original contributions related to Maritime Safety, Maritime Education, Maritime Management, Marine Engineering, Maritime Technology & Informatics, or other related fields.

ALAM is committed in inculcating research culture via AJMS, which serves as a platform for authors and researchers to share their knowledge and expertise across the stipulated research areas.

## **Editorial Board**

Advisor

Prof. Dr. Hamdan Suhaimi

Chairman

Ts. Dr. Capt. Manivannan Subramaniam

Editor-in-Chief

Dr. Saedah Sakidin

Editor

Dr. Ramesh Babu Amathalai

Mdm. Normaizura Mat Rom

Ts. Dr Capt Amir Syawal Kamis

Capt. Mohd Yusrino Taib

CE Azhari Md Noh

Reviewer

Capt. Cheng Kim Choon

Mdm. Nadia Harnisa Binti Abdul Rahman

Mr. Ravinjit Singh A/L Pritam Sin

Mr. Yiow Ru Vern

Secretary

Capt. Mohammad Monir Hossain

Member

Mdm. Hanim Zainal

Mr. Mohd Azizi Bin Hamid

Capt. Murugan Maripin

## **Copyright**

© Copyright 2022 Malaysian Maritime Academy (ALAM)

All contents in ALAM Journal of Maritime Studies (AJMS) shall be the property of ALAM unless otherwise stated. No parts of AJMS may be reproduced, transmitted, or copied in any form or means without the prior written consent of ALAM.

## **Cover Design**

MISC Group Corporate Communications

## **Publisher**

Malaysian Maritime Academy Sdn. Bhd. (ALAM)

Window Delivery 2051, 78300 Masjid Tanah, Melaka, Malaysia

Telephone No: +606-388 2200 Facsimile: +606-387 6700

Website: [www.alam.edu.my](http://www.alam.edu.my)

## Foreword by Ketua Eksekutif

Greetings!

Another year comes and with great pleasure, I would like to announce the arrival of AJMS Volume 4, Issue 1 2023, published online for the first time after its first publication in 2017. This is indeed a milestone achieved in the history of ALAM. Congratulations to the Editorial Board for the tireless effort and commitment to ensure that the publication materialized this year.

Volume 4 of AJMS has a mixture of articles representing different disciplines within the scope of maritime, ranging from maritime engineering up to Halal logistic and supply chain. The scope, indeed, has expanded and we have seen an increase of interest among ALAM academicians in writing academic articles.

I can never emphasize enough that AJMS is the platform where innovative ideas can be shared, technological advancement can be put into perspective, practical approach and improvements can be made possible or even venturing into bold new research. I have always believed that teaching is to disseminate knowledge, Research is to create new knowledge and Services as the sharing of knowledge.

In line with the AJMS policy, ALAM is committed in inculcating the research culture among ALAM community via AJMS, which serves as a platform for authors and researchers to connect and share their knowledge and expertise. It is hoped that a steady and consistent flow of publication will continue and finally AJMS be indexed in Scopus to put ALAM in the world map.

Last but not least, we also welcome researchers from academic or industry backgrounds to publish in AJMS, particularly the global maritime community.

Sincerely,



Prof. Dr. Hamdan B. Suhaimi,

Ketua Eksekutif,

Akademi Laut Malaysia (ALAM)

# ALAM Journal of Maritime Studies

Volume 04 Issue 01 June 2023

## TABLE OF CONTENTS

Automatic Changeover Discharge Valves of Sewage Treatment Plant.

*Naresh Gopal A/L R.Raju ~ Nirumal A/L Rajoo ~ Vignes Rao A/L Nagaraju Roo .....1*

Challenges Of E-Learning for Students in Akademi Laut Malaysia (ALAM).

*Siti Nur Afifah Binti Noordin Saleem.....12*

Alam's Ratings' Perceptions of Autonomous Ships.

*Amir Syawal Bin Kamis.....22*

Constructivism Learning Theory Applications in Maritime Engine-Room Simulator (ERS) and 21st-Century Classroom.

*Zaful Rullah Hakiem Bin Zaini.....31*

Navigating The Waters of The Maritime Industry: Challenges in Malaysia.

*Shahidah Binti Ahmad Suhaimi ~ Nadia Harnisa Binti Abdul Rahman ~ Zulkarnian Bin Ahmad ~ Chua Kim Muar ~ Ramesh Babu Amathalai ~ Nur Zulaikha Binti Samsudin ~ Aisyah Binti Othman ~ Ravinjit Singh Pritam Singh.....40*

Engine-Room Simulator (ERS) As Assessment Tool in Higher Education: Case Study of a Maritime Education & Training Institution in Malaysia.

*Zaful Rullah Hakiem Bin Zaini .....48*

Consumer Perception of Halal Logistics Practices in Malaysia: A Conceptual Review

*Shahidah Ahmad Suhaimi ~ Nadia Harnisa Abdul Rahman ~ Zulkarnian Ahmad ~ Chua Kim Muar ~ Ramesh Babu Amathalai ~ Nur Zulaikha Samsudin ~ Aisyah Othman ~ Ravinjit Singh Pritam Singh.....65*

**AUTOMATIC CHANGEOVER DISCHARGE VALVES OF SEWAGE TREATMENT PLANT**

Naresh Gopal A/L R.Raju \*  
nature400@gmail.com

Nirumal A/L Rajoo  
nirumal93@gmail.com

Vignes Rao A/L Nagaraju Roo  
vignes306@gmail.com

Corresponding author\*

*Student in Malaysian Maritime Academy, Melaka Akademi Laut Malaysia, BT 30 Kg Tg Dahan, 78200 Kuala Sungai Baru Melaka, Malaysia*

**ABSTRACT**

Water containing faeces, industrial waste, and debris such as rust and plastic made up of raw sewage. The effect of sewage on the marine environment is a source of concern. Pathogens, nutrients, detergents, pesticides, and heavy metals can all pollute seawater. As much as it could contaminate the sea, the environmental and health risks are also high for humans because the community shares the seawater for recreation, swimming, and food production. The sewage treatment system on most of the ships is designed to remove pollutants from sewage water before it is discharged into the sea. The basic principle of a sewage treatment plant on board is to treat and process raw sewage through a series of steps that include breaking, filtering, settling, controlled aerobic decomposition, and chemical treatment before it is discharged into the environment. The sewage water treatment system is one of the most important systems on board. According to MARPOL 73/78 of ANNEX 1V (Prevention of Pollution by Sewage from Ships), all ships 400 gross tonnage and above that carry more than 15 persons should have an approved sewage treatment plant. If the sewage is comminuted or disinfected, it can only be discharged overboard using a permitted sewage treatment plant 3 nautical miles from the nearest land. If the sewage is not comminuted or disinfected, the sewage may be discharged at 12 nautical miles from the nearest land when the ship is en route and proceeding in not less than 4 knots (Anish, 2021).

**ARTICLE INFO**

*Keywords:*  
*PIC16F84A*  
*microcontroller,*  
*Discharge Valve,*  
*Liquid Crystal*  
*Display (LCD),*  
*Nautical Mile,*  
*LED indicator,*  
*ECR Module*

## 1.0 INTRODUCTION

The use of a microcontroller to automate the changeover of sewage treatment plant's discharge valves could benefit the maritime industry by preventing unnecessary fines imposed by port authorities due to ship staff's failure to follow MARPOL regulations, MARPOL Annex IV to be exact. Aside from that, our primary goal is to reduce crew working hours while also ensuring that our coastal waters are not contaminated with sewage, which could cause a variety of biological ecosystem issues. We could use this technology to automatically send a signal to the discharge valve to either switch over to the sewage holding tank or discharge it overboard according to the distance from the nearest shoreline. This system also has a fail-safe mode whereby a manual override selector is given. In the event of an emergency or maintenance, or if the ship is in a special area that does not allow overboard sewage discharge, the operator can manually operate the discharge valve. A microcontroller receives input signals from the vessel's navigation system with regard to the distance of the vessel to the nearest shoreline, as commonly found in an Electronic Chart Display and Information System (ECDIS), which then generates an output signal to change the direction of sewage discharge accordingly. Using the PROTEUS software, we are able to simulate the project's working principle as well as test the operation of the discharge valve with a visual display and indicator. The digital circuit operating using a microcontroller is programmed using the PIC C Compiler.

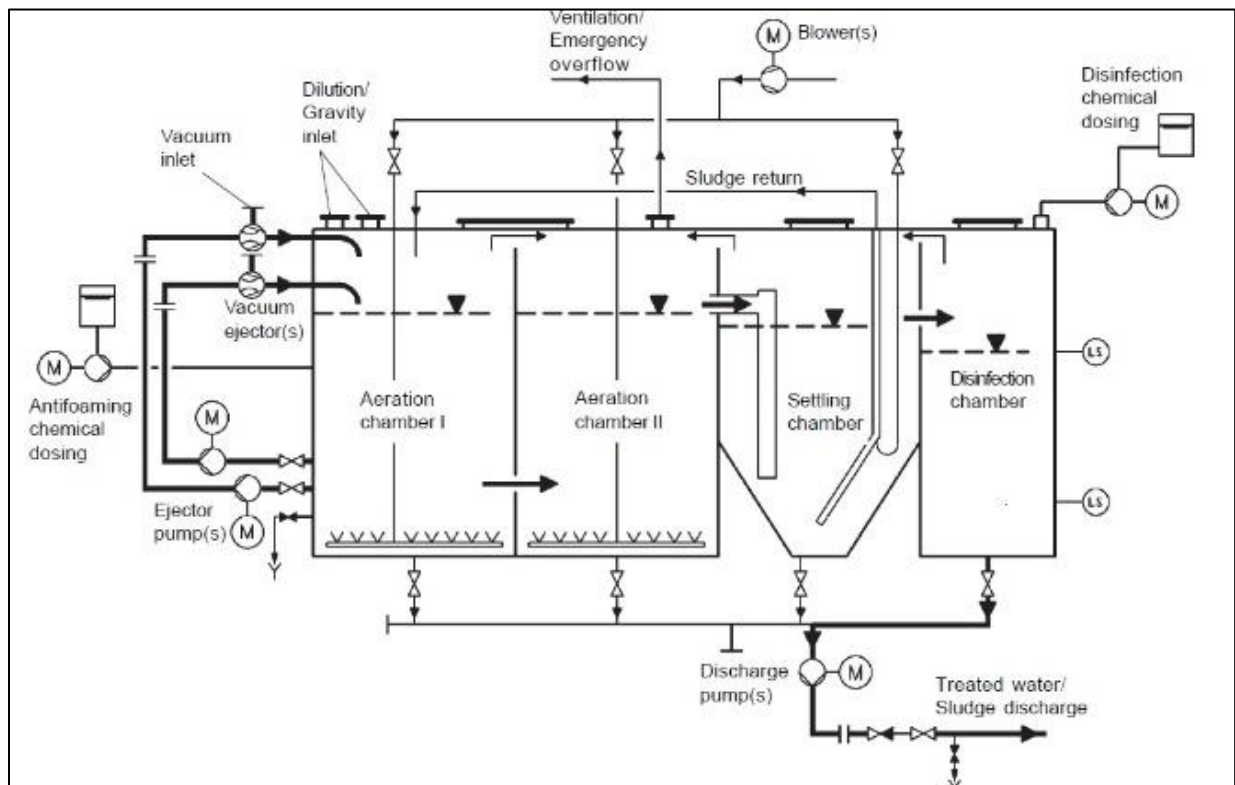

Figure 1: Sewage Treatment Plant Line Diagram (Firoz, 2015)



## **1.1 PROPOSED SYSTEM**

A simple, dependable, configurable, easy-to-monitor, and electronically operated control system is proposed to provide useful assistance and improve the productivity of crew and vessels. By introducing this system, human error could be avoided, and it would benefit the environment.

## **2.0 METHODOLOGY**

This intended technology is being proposed to swap discharge valves, which simplifies ship control automatically. The operator of the traditional system must manually switch valves at appropriate times to discharge wastewater overboard. This project was designed to improve and ease the burden of engineers on board ships, as there had been incidents where the crew overlooked the discharge and mistakenly left the overboard line open while the vessel was docked. This led to a major issue involving the Port Authority, and the vessel was detained until the company paid for the consequences. The research was done extensively based on current issues onboard vessels, either online or through individual experiences. It was decided to modify the manual valve system to automatically change the discharge valves that could be programmed accordingly. Knowing there could be an issue electronically and electrically, a manual override system is placed in case any emergency occurs.

## **2.1 COMPONENTS**

The entire Digital Circuit consists of several components that replicate or reflect those that can and would be used in an original final product.

1. PIC16F84A, 18-pin Enhanced FLASH/EPROM 8-bit Microcontroller
2. LM018L, 40x2 Alphanumeric LCD
3. 10WATT470R, 470R 10WATT Resistor
4. LED-GREEN, Animated LED
5. LED-YELLOW, Animated LED
6. LED-RED, Animated LED
7. LED-BLUE, Animated LED
8. 4070, Quad 2-Input EXCLUSIVE-OR Gate
9. SW-ROT-3, Interactive 3 position switch
10. BUTTON, Push Button
11. MOTOR, Simple DC Motor
12. T73S5D15-5V, 10 Amp Miniature PCB Relay
13. SW-SPDT-MOM, Interactive SPDT Switch

## **2.2 OPERATION**

The operation of the system can be divided into two parts, Automatic Operation and Manual Operation. The user is given the freedom to choose to operate the system either automatically or manually. In AUTO Operation, the Primary MCU reads and analyses the signal from the

vessel's navigation system. The Primary MCU then sends out the output signals accordingly to control the discharge valve, LED indicators, and Secondary MCU. The Secondary MCU receives its input and sends the relevant output to the LCDs to indicate the distance range as well as the discharge valve status. In MANUAL operation, the system will no longer control the discharge valves, which means no output signal is sent from MCU to the discharge valves. This will allow the user to operate the valve manually. Manual operation is essential as there are Special Areas more than 12Nm from the nearest shoreline which does not allow sewage discharge into the sea. Apart from that, the 3 to 12Nm range is very subjective and crew or users may opt to operate the system as they wish when there is a manual mode. The operation is further discussed in depth in the sub-topics below.

### 2.3 TRUTH TABLE

The input and output variables are defined and shown in the table below.

INPUT				OUTPUT							
PIN A0	PIN A1	PIN A2	PIN B0	PIN B3	PIN B4	PIN B5	CM	PIN A3	PIN B1	PIN B2	PIN B6
NM0	NM3	NM12	ML	SOL1	SOL2	SOL3		RL	YL	GL	BL
1	0	0	0	1	0	0	0	1	0	0	0
0	1	0	0	0	1	0	1	0	1	0	0
0	0	1	0	0	0	1	1	0	0	1	0
0	0	0	1	0	0	0	0	0	0	0	1

Table 1: Truth Table of System

### 2.4 MICROCONTROLLERS

PIC16F84a is an 8-bit PIC Microcontroller with enhanced EEPROM that is a successor to PIC16C84, which was introduced in 1993 by Microchip Technology to simplify electronic tasks that require no or minimal skills to achieve hands-on experience working with them. The PIC16F84a has an 8-bit timer and a serial programming interface, particularly useful for laying out serial communication with other devices. It has 64 bytes of EEPROM (primarily used for storage of data), 1K program memory (indicates the amount of code that can be burned inside the controller), and 68 bytes of data memory (RAM). It surpasses its predecessor in terms of compatibility (Microchip Technology, n.d.).

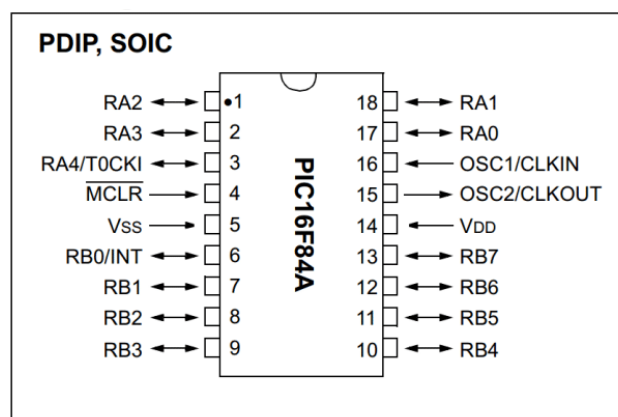

Figure 2: PIC16F84a Microcontroller Pin

## **2.5 SOFTWARE**

The PIC16C84 was introduced in 1993 and is credited with being the first PIC microcontroller to include a serial programming algorithm and EEPROM memory (it was preceded by the Motorola MC68HC805B6 and MC68HC805C4 along with the MC68HC11E2 with serial bootloader and EEPROM program storage released in the late 1980s). These chips are ideal for tech enthusiasts as they only require an inexpensive programmer to program, erase, and re-program the chip. As PIC16C84 supplies became scarce due to its discontinuation, the PIC16F84 gained in popularity as a near-drop-in replacement. Since the programming algorithm was different, new programming software was required, but the programming hardware required remained the same. Even later (1998), Microchip Technology launched the improved PIC16F84A, allowing faster clock speeds (up to 20 MHz), faster programming, and a reduced current draw. The PIC16x84 microcontroller is part of Microchip's 14-bit series (the instruction word size for all instructions is 14 bits), making the '84 a good development prototype for other similar but less expensive one-time-programmable 14-bit devices (Microcontroller Lab, n.d.).

## **2.6 PROGRAMMING DESCRIPTIONS**

The software PROTEUS is used to create the prototype circuit, and the program that controls the entire operation is written in the C language of the PIC16C84A microcontroller. CCS compilers are used to compile the codes, and the programs are assessed.

## **2.7 SYSTEM FLOW**

The auto changeover of Sewage Plant Discharge valves works based on the principle of how far the ship is located from the nearest shoreline. The primary MCU will receive data from the vessel's navigation system, which will then be analysed by the MCU. The processed data will then send an output signal based on the distance range setting in the MCU. The discharge valve is automatically changed depending on the distance range from the nearest shoreline. The distance range and valve status will be shown in the LCD unit at both local and remote (ECR) locations. LED indicators are also installed at both locations to indicate the current distance range of the vessel (Refer to Figure 3).

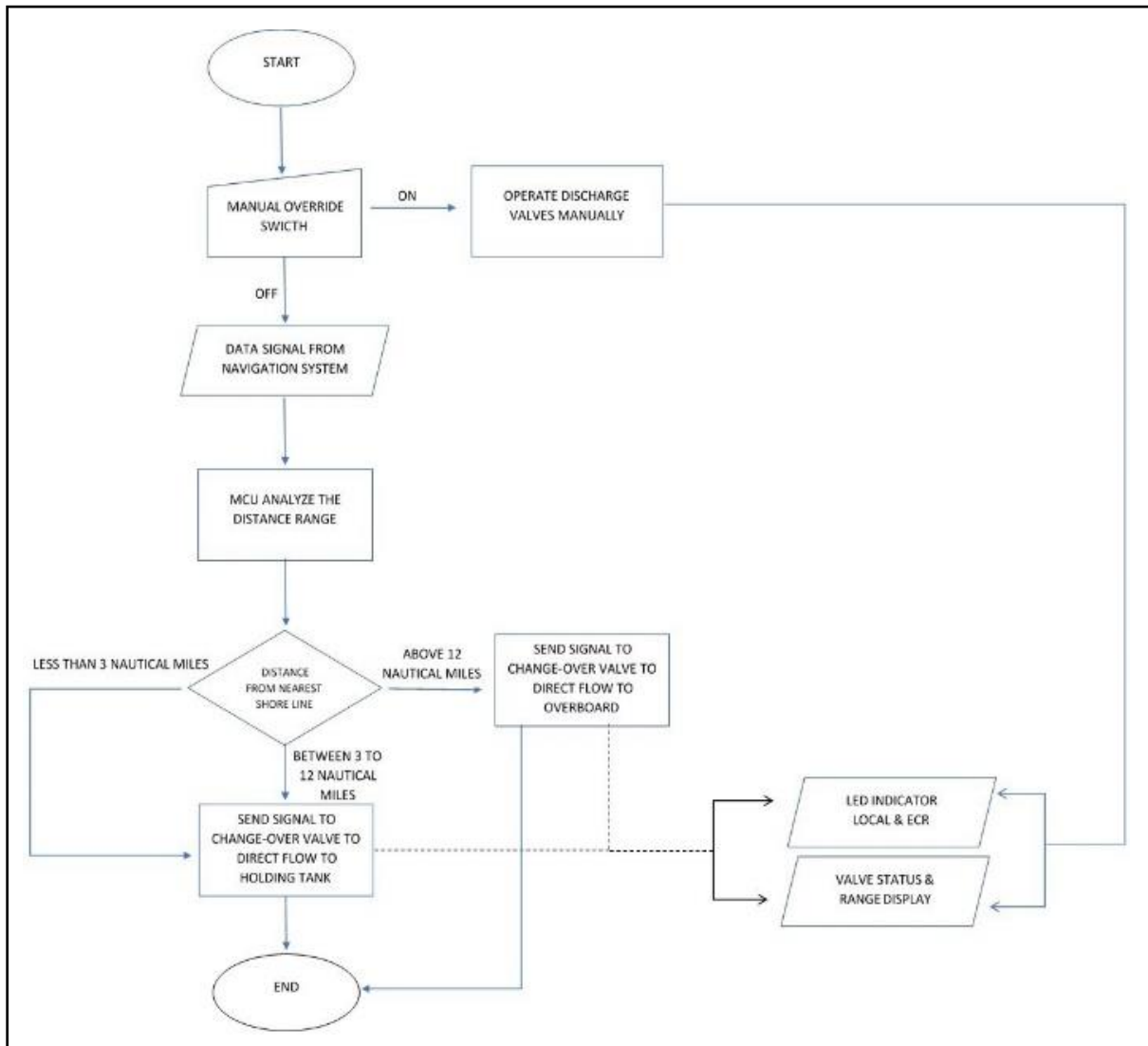

Figure 3: Flow Chart of Proposed System

## 2.8 CIRCUIT

The whole circuit is made up of two Microcontrollers, which can be divided into two different modules. One module is for the Local side, which is at the Sewage Treatment Plant itself, and the other is on the Remote side, which is the Engine Control Room. One primary MCU is responsible for the major operation of the auto changeover of the discharge valve as well as for the indicators or vessels' current distance range from the nearest shoreline in terms of LED. The input of the primary MCU is derived from the vessel's navigation system, which is then interpreted by the MCU for its relevant output. In the schematic diagram, a 3-way ROT Switch is used to represent/stimulate the different ranges of input received from the navigation system (Figure 4). The same input is extracted to the second MCU as labelled in the schematic diagram.

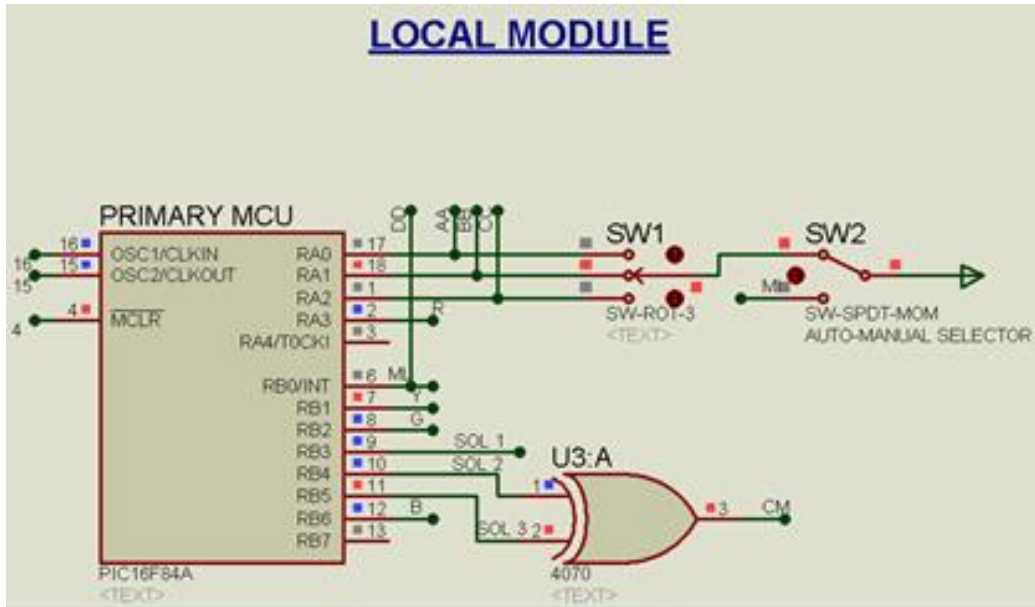

Figure 4: Primary MCU, SW1, and SW2

Depending on the input received, the output is broken down into two parts, the first part being the output to control the discharge valve changeover. An electric signal is sent to an Electro-Pneumatically operated valve (Figure 5). As two outputs are being directed to change over to the Holding Tank position, we have used a Quad 2-Input EXCLUSIVE-OR Gate so as to not interrupt the signal during the changeover between the first two ranges (Refer to Figure 5, component U3:A).

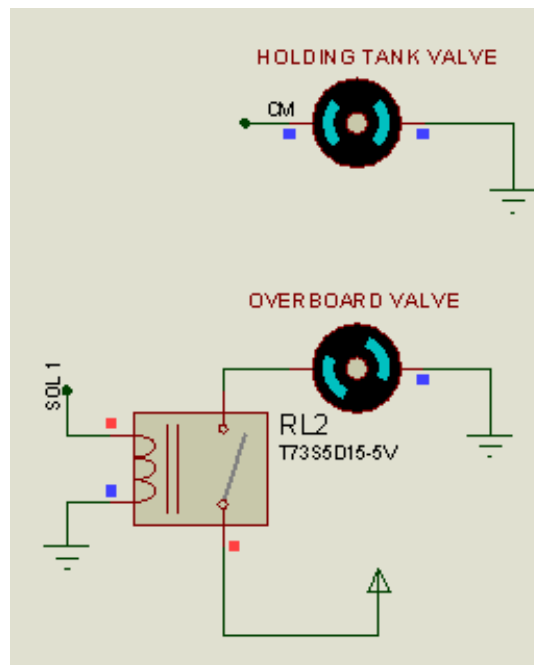

Figure 5: Sewage Holding Tank and Overboard Valve

The second part of the output for the primary MCU is for the LED indicators, which provide the user with a visual and simple identification of the vessel's position from the nearest shoreline. Four different LEDs are used; Red (Less than 3 N.M.), Yellow (3 to 12 N.M.), Green (More than 12 N.M.), and Blue (Manual Operation). These outputs are commonly supplied for all LEDs located at the Local (Figure 6) and Remote side (Figure 7).

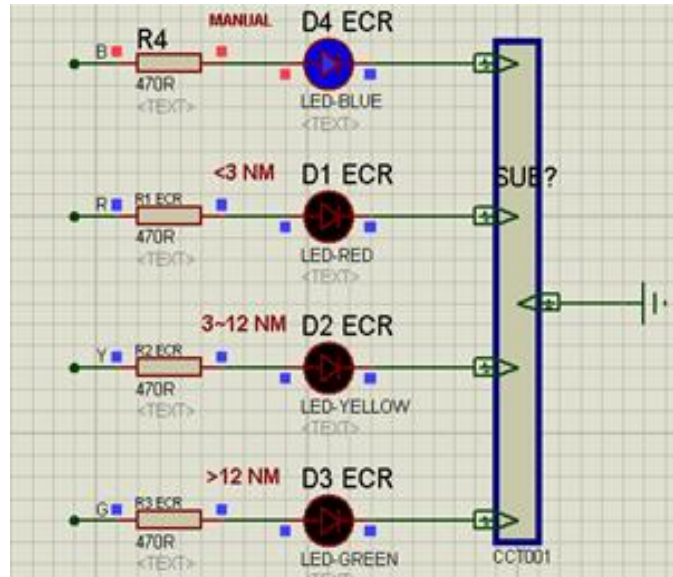

Figure 6: Light Indicator at STP local

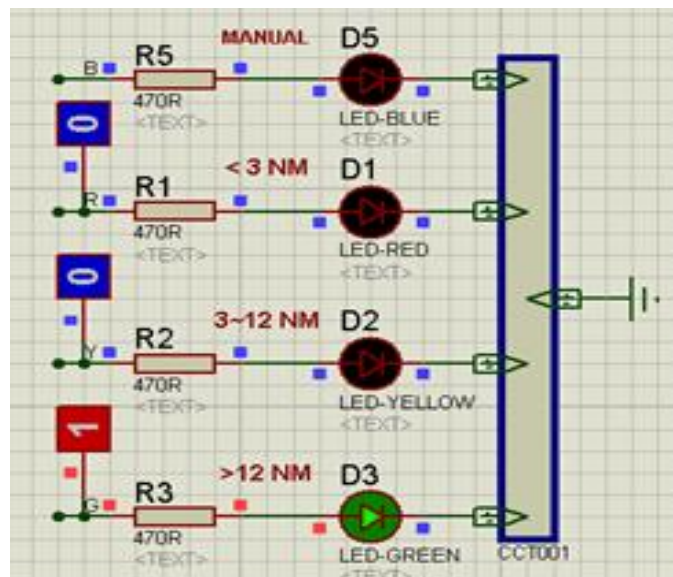

Figure 7: Light Indicator at ECR

A secondary MCU is used to program and power up the LCDs (both local and remote side) to indicate the Discharge Valve status and the distance range of the vessel from the nearest shoreline (Refer to Figures 8, 9, and 10).

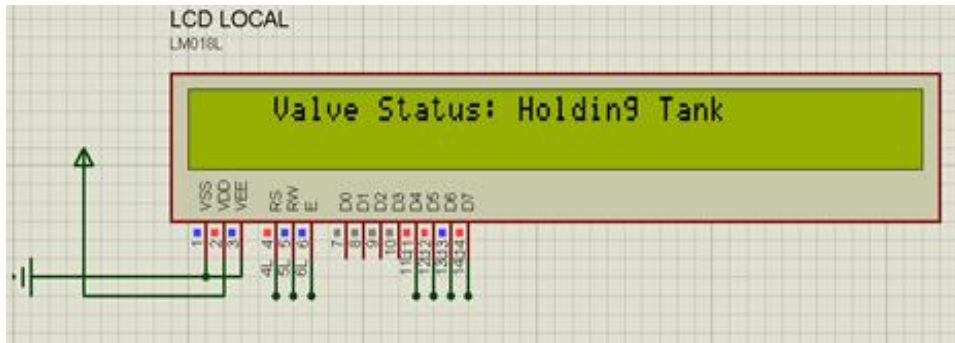

Figure 8: LCD at STP Local

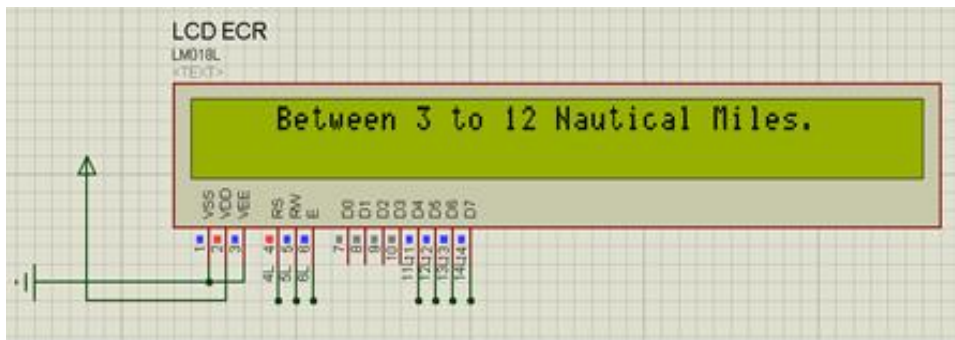

Figure 9: LCD in ECR

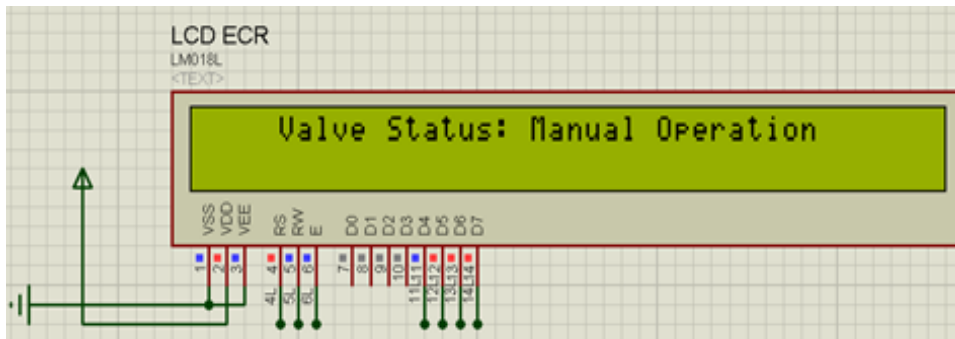

Figure 10: LCD in ECR Local

### 3.0 CIRCUIT DESIGN SIMULATION

This electronic circuit (Figure 11) was created using PROTEUS 7 Professional software and programmed using the PIC C Compiler. PROTEUS 7 Professional has almost all the components required to stimulate and visualise the actual project being created. Using this software has enabled us, the designers and creators of this project, to further understand the behaviour, flow, and operation of the actual circuit. Multiple trials have been carried out after designing and programming the MCU, and the outcome shows good performance and results. A 3-way ROT Switch was used to stimulate the different distance range picked up from the vessel's navigation system, which is then interpreted by the MCU to give out the right output and change over the discharge valve accordingly. In addition to that, usage of the LCD Module, which enables us to display the relevant data, makes it more user-friendly, especially in both



Local and Remote locations. Overall performance, accuracy, and outcome of the digital circuit are good.

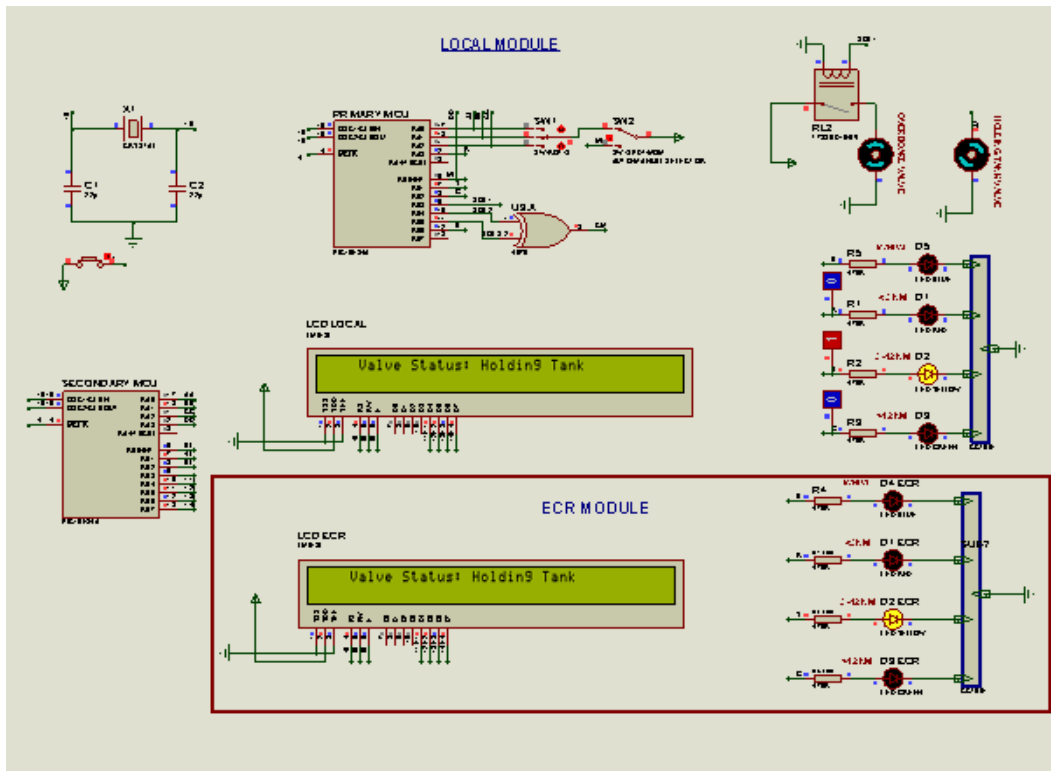

Figure 11: Circuit Design Simulation

#### 4.0 RECOMMENDATIONS

Based on the results achieved from the digital circuit simulation, and as to relate to the purpose of this project, the authors would like to suggest that besides having such a system installed onboard ships to ease the operation, ship crew shall always be vigilant and up to date with the regulations updated by MARPOL with regards to MARPOL Annex IV as certain Special areas can be outside the 12 nautical miles mark and would require the system to be switched to Manual Operation. The best would be to make this compulsory for all ships to install the system; then, it will be much easier to consult with MARPOL itself to update the existing program whenever there is a change in regulation. This way, all ships would be complying with an automatic system.

#### 5.0 CONCLUSION

Most of the designs on the vessel focus primarily on technological advancements in their sewage treatment plant, but the existing valve systems onboard remain unchanged. The international community is concerned about marine oil pollution because it has had significant negative impacts on the ecological environment, human security, and economic development. With increasingly stringent environmental protection laws and standards, vessels must exercise greater caution when dealing with MARPOL law-breaking. The authors believe that this system will undoubtedly shift toward efficiency and environmental protection in the future.



## 6.0 ACKNOWLEDGEMENTS

Primarily, we would like to express our heartfelt appreciation to our lecturer, Dr Ramesh Babu Amathalai, for his unwavering support in helping us whenever we needed it, as well as his patience, motivation, enthusiasm, and vast knowledge. His advice was immensely valuable throughout the research and writing of this article. Aside from our advisor, we would like to thank the rest of our ACSU46 classmates for their insightful comments and assistance. Finally, we would like to thank our family for their emotional support during this semester.

## REFERENCE

- Abhishek, A. (2019, March 20). *Sewage Treatment Plant Design and Working*. (ShipFever). Retrieved from <https://shipfever.com/sewage-treatment-plant/>
- Anish. (2021, July 12). *Sewage Treatment Plant on Ships Explained*. (Marine Insight). Retrieved from <https://www.marineinsight.com/tech/sewage-treatment-plant/>
- Chandrasekhar, B. (n.d.). *MarineSiteInfo.com*. (Marine Site Info). Retrieved from <https://www.marinesite.info/2021/06/marine-sewage-treatment-plant-on-ship.html>
- Fairchild Semiconductor. (1999, January). *CD4070BC*. Fairchild Semiconductor.
- Firoz. (2015, September 30). *Marine Engineering Study Material*. Retrieved from <https://marineengineeringonline.com/biological-vacuum-sewage-treatment-plant-on-ships/>
- Hemath Naveen K.S, H. P. (2017, March 3). Sewage Treatment Methodology-A Review. *International Journal of Engineering Trends and Technology (IJETT)*, 45(3), 3. Retrieved from <http://ijettjournal.org/2017/volume-45/number-3/IJETT-V45P226.pdf>
- Microchip Technology*. (n.d.). (Microchip Technology Inc) Retrieved from <https://www.microchip.com/en-us/product/PIC16F84A#>
- Microcontroller Lab*. (n.d.). Retrieved from <https://microcontrollerslab.com/pic16f84a-microcontroller-introduction-and-features/>
- The PIC16F84A - A Beginners Microcontroller*. (n.d.). (TM Microcontrollers). Retrieved from <https://www.teachmemicro.com/pic16f84a-beginner-microcontroller/>
- Žarko Koboević, Ž. K. (2009). Marine Sewage Treatment Systems. (Ž. K. Žarko Koboević, Ed.) *Comparison of Marine Sewage Treatment Systems*, 10.

---

**CHALLENGES OF E-LEARNING FOR STUDENTS IN AKADEMI LAUT MALAYSIA (ALAM)**

Siti Nur Afifah Binti Noordin Saleem  
[sitinurafifah@alam.edu.my](mailto:sitinurafifah@alam.edu.my)

*Training And Education Division, Melaka Akademi Laut Malaysia, BT 30 Kg Tg Dahan, 78200 Kuala Sungai Baru Melaka, Malaysia*

---

**ABSTRACT**

The novel coronavirus identified as Covid-19 disease affected the education sector at the end of 2019. The disease has significantly impacted the education sector, especially the students and educators. The students must sacrifice to adapt to the new norms to continue online learning (E-Learning) instead of face-to-face learning. This disease directly impacts the educational system, such as institutional, informal, and non-formal education, closed face-to-face learning progress, and requires a shift towards online learning. The main objective of this research paper is to analyse the students' challenges and responses during online learning. This questionnaire was given to 40 students of Akademi Laut Malaysia (ALAM) in the cohort/batch of DME 41 and DNS 27. The results of this research explain that most students faced the challenges of connectivity issues and distractions from family members. The challenges significantly impact their studies, where the students find it difficult to focus in class. Based on the data, ALAM students have an average understanding of online learning. Some of them immensely enjoyed online learning.

**ARTICLE INFO**

*Keywords:*

*Covid-19, online learning (E-Learning), education sector, challenges*

---

**1.0 INTRODUCTION**

According to Huang et al. (2020), in the previous year of 2019, a new virus known as Covid-19 was discovered in a seafood market in Wuhan. The clinical investigation of the virus indicated that it passed from person to person. Li et al., (2020) and Paules et al. (2020) refer to a pandemic as “a disease epidemic that spreads over a large geographic area and affects a disproportionately large proportion of the population”. This situation directly affects the educational system, where institutional, informal, and non-formal education has abandoned face-to-face learning in favour of online learning (E-Learning). The transition from face-to-face to online learning presents several challenges for instructors, especially when it occurs without any warning. Educators have used online channels to reach out to kids, webinars have acted as temporary classrooms, parents have been pushed to watch children at home, and students have been denied social connection with their classmates (Elsa R. et al., 2020).

The government's call to fight Covid-19 collaboratively by avoiding complex activities, social distancing, and psychological distancing, limiting leaving the house through work from home (WFH), and optimising activities that can be carried out remotely through the online system has had a significant impact on the educational system (Carducci et al., 2020). However, making the switch from traditional classroom instruction to online learning may be challenging (Mailizar et al., 2020). The Ministry of Education encouraged all institutions to switch to online classrooms to continue the education process. Unfortunately, the government should have been more flexible in adopting this scheme without first determining whether or not the lecturers were prepared. Similar conditions occurred in other nations (Almaiah et al., 2020).

The term "online learning" refers to using the World Wide Web and other key technological developments to develop and distribute course materials, conduct instruction, and administer educational programmes. There are two forms of online learning, asynchronous and synchronous online learning, which are compared extensively. However, for online learning to be effective and efficient, instructors, organisations, and institutions must be thoroughly aware of its benefits and drawbacks (Naemah et al., 2022).

The advent of online courses requires a considerable change in the communication patterns between lecturers and students, summative evaluations, and material delivery. One major issue was that few professors were qualified to teach online courses, especially those entirely online. (Reyes et al., 2020). On the other hand, E-learning was predicted to positively impact motivation, independence, and student engagement (Moreno et al., 2020). Mailizar et al., (2020), concluded that students' voices are important in this debate. Therefore, this study aims to examine students' thoughts and opinions on online learning during an outbreak.

Insufficient access, a lack of internet accessibility, a lack of technology and students' capacity to engage in digital learning, as well as a lack of an appropriate connection with instructors are just a few of the challenges that Zhong (2020) claims have had a significant impact on the implementation of online learning. Virtual classrooms will not appeal to those who learn best via physical interaction, and the absence of traditional classroom interactions is a critical component of online learning. Real-time exchange of ideas, knowledge, and information is constrained in the virtual learning environment since students can only communicate with their classmates digitally and not physically see them (Claudiu Coman et al., 2020).

## **2.0 LITERATURE REVIEW**

Due to the pandemic, educational institution needs to be done in e-learning. Educators need to change their style of learning from physical classes to e-classroom. One of the challenges educators face is understanding students' learning styles during online classes. This is because each student has a preference for learning. Some prefer to learn using visual presentations, listening to instructions and writing notes (Islam et al., 2015). Academicians need to be expert and competent in their knowledge and be concerned with student learning styles so that educators can deliver their subject according to student learning styles. Educators are expected to recognise a variety of learning styles to help the students in their e-learning (Gopal et al., 2020). Educators must be familiar with the technology to have a successful learning experience. When educators have been trained to enhance their ICT skills to make meaningful e-learning, it can motivate and encourage the educators toward the positive outcomes of e-learning technology (Islam et al., 2015).

Time management is another challenge faced by educators. Educators struggle to manage their time (Islam et al., 2015). Maatuk et al. (2022) stated that educators need to communicate better with students during this pandemic due to no physical classes; educators need to have a

discussion page and visit at least once daily to ensure students' enquiries are answered. Educators must constantly engage with students by giving feedback and providing answers so they are not excluded from the syllabus. There are research says that online learning consumes 30% more time than physical classes (Islam et al., 2015).

Research from Aboagye and Yowson (2021) found students' challenges in dealing with online classes and whether they have prepared to study online. Most of them must prepare their gadgets, internet connection, and mental readiness. Online learning can be challenging because of the lack of face-to-face contact between students and lecturers. This will affect the motivation of the students to have online learning (Samir et al., 2014). The data from 82.29% of university students in India reported having a willingness to study online. It proves that most students have tried adapting a new norm to online learning, and it also shows there has been an improvement in self-study skills. Providing helpful materials from universities and lecturers motivates students to focus during online learning. Some students preferred physical classes because they had the opportunity to discuss, debate, and deliberate with their classmates and friends. They also prefer physical classes for practical sessions rather than online classes (Maatuk et al., 2021). Students feel that different learning styles affect students.

### 3.0 FINDINGS AND DISCUSSION

The researchers used a questionnaire as an instrument to conduct this research. There are nine questions in the questionnaire distributed to 40 students enrolled in the Diploma in Marine Engineering (DME) and Diploma in Nautical Studies (DNS). The students have provided their responses based on the questionnaire.

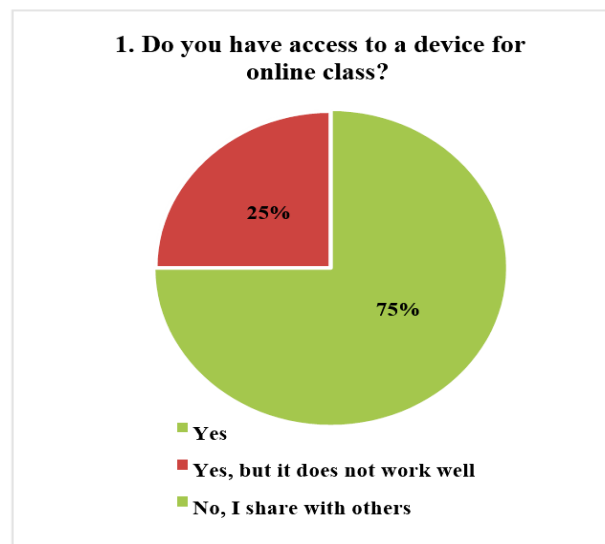

Figure 1: Data for the Access Device

Based on Figure 1, the first question in the questionnaire regarding the accessibility of devices during online classes, 75% of students responded that they have their own devices to access the classes. The balance of 25% of students have the devices, but the device does not work well during online classes. This is due to the technical issues of the devices. The devices might have slow software or a lack of internet connection causing the devices not to work well during the online classes.

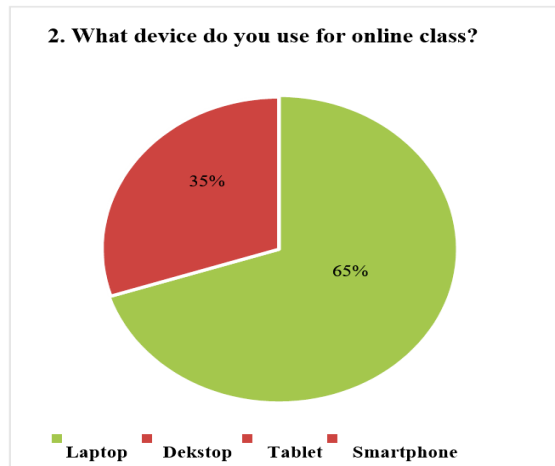

Figure 2: Accessibility of Device

Figure 2 shows that 65% of students use laptops as their devices during online classes, whereas the other 35% only use smartphones as their devices. The students who only use smartphones as their devices will cause a lack of focus during class due to the smaller size of the smartphones compared to those who use laptops as equipment for online education at home. Currently, the government has offered the students facilities where each student will be provided with a tablet as the device needs to be used during online classes.

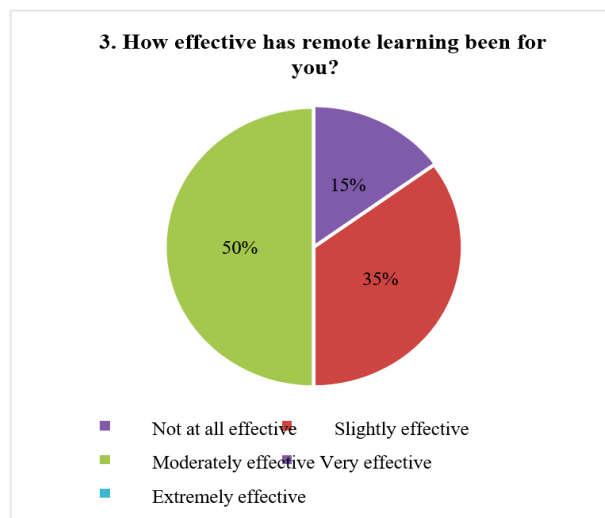

Figure 3: Effectiveness of Remote Learning

According to Figure 3 above, 50% agree that remote learning is moderately effective. This shows that the lecturer’s academic delivery in class can be improved by having the lecturers put in extra effort during the lecture delivery. As such, the lecturers may include quizzes, online games, animation videos, and many more to improve the effectiveness of online lectures. Next, 35% of students agreed that remote learning is slightly effective. The reason is that the students have to imagine and be creative to understand certain subjects. 15% of students mentioned that online classes are ineffective. The students might have difficulties understanding online classes because of their devices or surroundings.

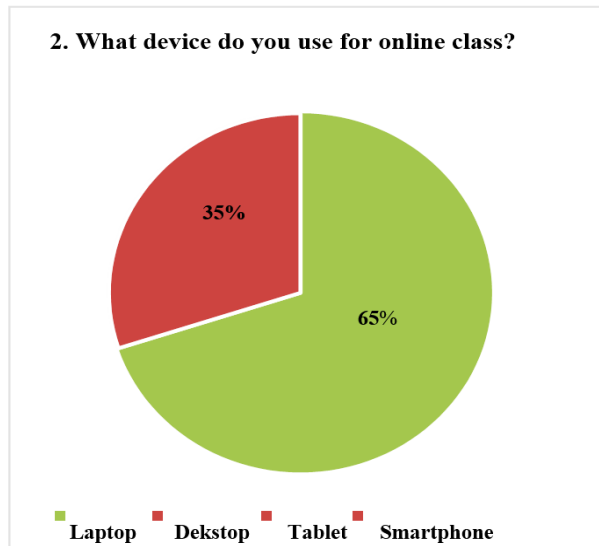

Figure 4: Time Spent by Students

In ALAM, the students usually have around 6 hours of classes per day according to the class timetable. By referring to Figure 4, 75% of students agreed that the students are using about 5-7 hours per day for online classes, and 25% spent 7-10 hours per day for online classes. This is mainly because some students will have extra classes or tutorials, which causes the students to spend extra hours completing the tutorials and assignments given by the lecturers.

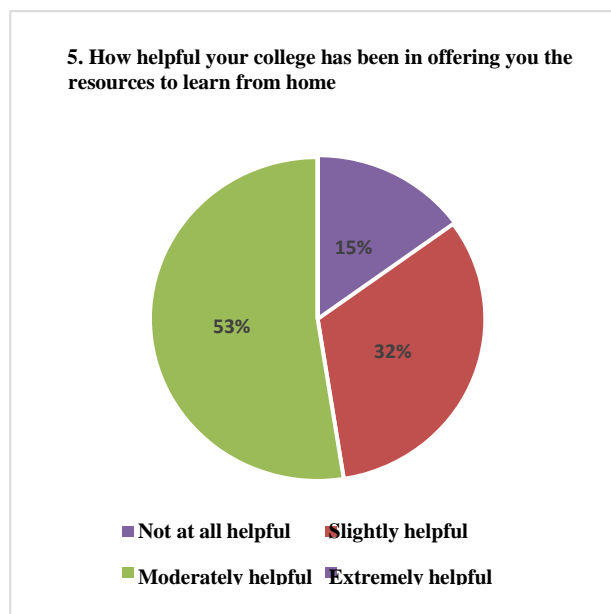

Figure 5: Favor Response from Friends

Based on Figure 5, the majority has voted for moderately helpful, at which the percentage is 53%. This percentage shows that the knowledge sources are limited because the students only depend on lecture notes and internet sources. If the students are on campus, the students may have consultation hours with the lecturers, enhancing the sources of knowledge.

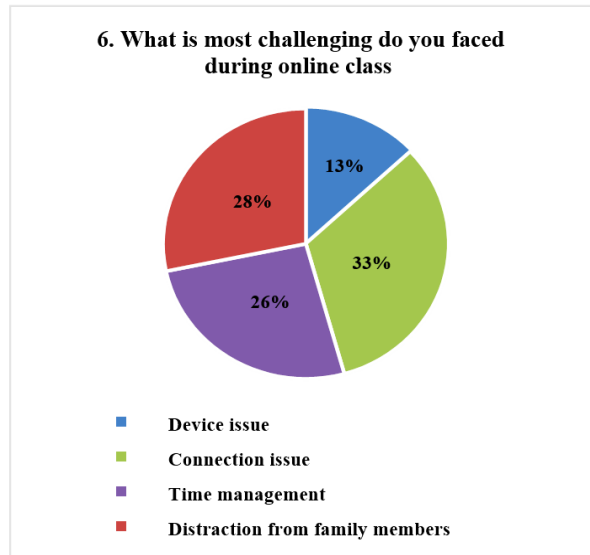

Figure 6: Factors of Challenges

Based on Figure 6, most students voted for the connection issues, which are bound to happen in an online-only environment. The technical and connection issues add to the online environment’s frustration and interrupt new distance learning sessions. Technical issues will happen when the students’ computers shut down, or there are moments when Wi-Fi is spotty, and weak monitors can make it challenging to keep up with virtual classmates and the learning environment. The students must be alert that a reliable internet connection is critical. The students must have a fast home internet connection where the high-quality home service will help to avoid any connection issues. Moreover, the students need to find areas where Wi-Fi-connected places are stable for classes, such as a public library or coffee shop.

The most critical stage is to communicate with and inform the professors. In order to accommodate challenging connection scenarios, the instructor and students should be more understanding and adaptable. It can be highly advised that the professors take the initiative to record class sessions using learning platforms as a backup.

The students then cast their votes for time management. Since the time management technique is solely dependent on self-motivation, it may be the most challenging obstacle for students. The students must make studies a priority and develop autonomous time management skills. The students must choose the time and location where the schoolwork will be finished. These days, social media and internet surfing might divert students from their studies. When you need to concentrate on studying, it is advised to use techniques to shut off these distractions, such as distance learning and other time-wasters. The students may also accomplish more by making a to-do list for the week or each day and planning the optimal times for each assignment.

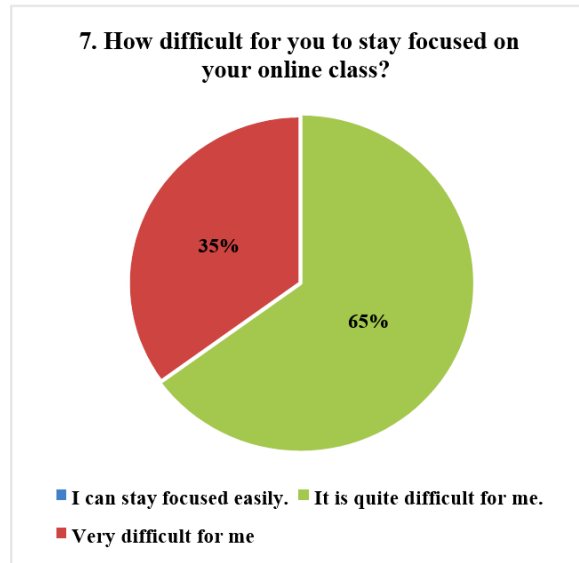

Figure 7: Data for Students' Focus in Class

Figure 7 shows the students' difficulties staying focused in online classes, giving the 65% and 35% votes. The students have selected an exceptionally difficult and very difficult to focus on in class, respectively. The difficulties come from many aspects; for example, mentioned in the previous question are device issues, connection issues, time management, and distraction from family members. Nora Mahpar (2021) agreed with this statement, mentioning the main issues with E-Learning where students are absent during online classes. The students reported their absence due to an unstable internet connection. Therefore, the teachers also admit that some students become fatigued, causing a decline in attendance. This shows that the data obtained from the students is valid compared to other researchers' data.

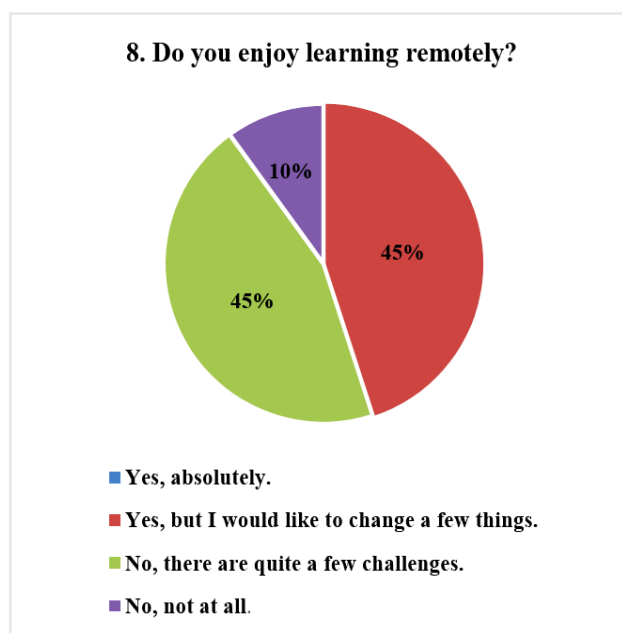

Figure 8: Students Feeling



Based on the data in Figure 8, the students voted for online learning, where almost half of the students enjoy online classes but need to change a few things. Then, almost half of the students faced challenges during online classes. Therefore, 10% voted did not enjoy online learning at all. This shows that each student has challenges in continuing studies at home. So, based on the questionnaire, the students have suggested making the online class more enjoyable. Firstly, the student requested the government to improve internet coverage in Malaysia. Next, the students requested more flexible hours for the online classes. The students might be tired due to the long screen time, so the colleges or schools can rearrange the schedule to more flexible hours for students.

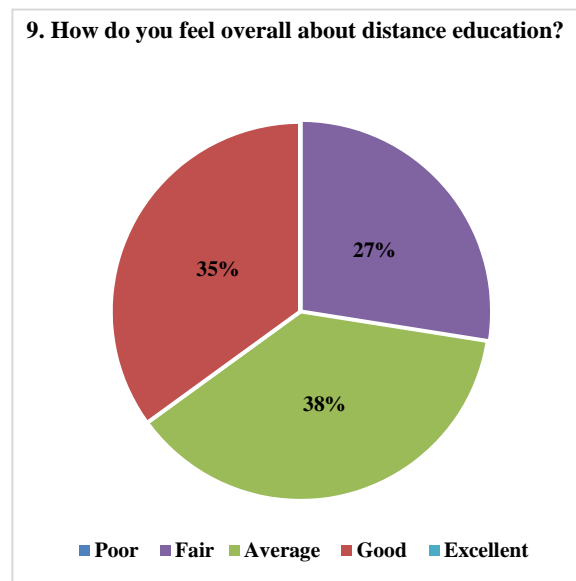

Figure 9: Overall Satisfaction

Figure 9 shows that 38% of the students rated the overall online class as excellent, and another 35% mentioned they were in good condition during class. So, the total good and excellent give the 50% of the online class's satisfaction, whereas there is a balance of 50% mentioned as they only rated as a fair and poor condition. According to the data, 50% of students are satisfied with the conduct of online classes, and 50% are unsatisfied with online classes. This is due to the students might have difficulties with devices or surroundings during online classes.

#### 4.0 CONCLUSION

This syndrome has a direct impact on the educational system. Institutional, informal, and non-formal education closed face-to-face learning progress and started adapting to the new norms of online learning (E-Learning). Due to the tight schedule, ALAM students have 5-7 hours of screen time daily. Most ALAM students have laptops to access online learning and feel that e-learning is moderately effective. This is because most students face the challenges of connectivity issues and distractions from family members. The challenges significantly impact their studies, where the students find it difficult to focus in class. Based on the data, ALAM students have an average understanding of online learning. Some of them immensely enjoyed online learning. Still, the students have requested certain things, such as the lecturer sharing videos of the lecture sessions with the students. The lecturer should conduct the class more slowly and give ample materials for each subject.

## REFERENCES

- Aboagye, E., Yawson, J. A., & Appiah, K. N. (2021). COVID-19 and E-learning: The challenges of students in tertiary institutions. *Social Education Research*, 1-8.
- Almaiah, M. A., Al-Khasawneh, A., & Althunibat, A. (2020). Exploring the critical challenges and factors influencing the E-learning system usage during the COVID-19 pandemic. *Educational Information Technology*, 25\*, 5261–5280.
- Carducci, A., Federigi, I., Dasheng, L., Julian R, T., & Marco, V. (2020). Making waves: Coronavirus detection, presence and persistence in the water environment: State of the art and knowledge needs for public health. *Water Research*, 179\*, 115907. <https://doi.org/10.1016/j.watres.2020.115907>
- Claudiu Coman, Laurentiu Gabriel T., Luiza Mesesan-Schmitz, Carmen Stanciu, & Maria Cristina Bularca. (2020). Online teaching and learning in higher education during the coronavirus pandemic: Students' perspective. *Sustainability*, 12\*, 10367. <https://doi.org/10.3390/su122410367>
- Elsa R., Nasrullah, & Eka Puteri E. (2020). Teacher's challenges towards online learning in pandemic era. *LET: Linguistics, Literature and English Teaching Journal*, 10\*(2), 71–882. <http://jurnal.uin-antasari.ac.id/index.php>
- Gopal, R., Singh, V., & Aggarwal, A. (2021). Impact of online classes on the satisfaction and performance of students during the pandemic period of COVID-19. *Educational Information Technology*, 26\*, 6923. <https://doi.org/10.1007/s10639-021-10523-1>
- Huang, C., Wang, Y., Li, X., Ren, L., Zhao, J., Hu, Y., ... & Cheng, Z. (2020). Clinical features of patients infected with 2019 novel coronavirus in Wuhan, China. *The Lancet*, 395\*(10223), 497–506. [https://doi.org/10.1016/S0140-6736\(20\)30183-5](https://doi.org/10.1016/S0140-6736(20)30183-5)
- Hrastinski, S. (2008). Asynchronous and synchronous E-learning. *Educause Quarterly*, 31\*(4), 51–55. <https://er.educause.edu/-/media/files/article-downloads/eqm0848.pdf>
- Islam, N., Beer, M., & Slack, F. (2015). E-learning challenges faced by academics in higher education. *Journal of Education and Training Studies*, 3\*(5), 102-112.
- Li, Q., Guan, X., Wu, P., Wang, X., Zhou, L., Tong, Y., ... & Xing, X. (2020). Early transmission dynamics in Wuhan, China, of novel coronavirus–infected pneumonia. *New England Journal of Medicine*, 382\*, 1199–1207. <https://doi.org/10.1056/NEJMoa2001316>
- Mailizar, Almanthari, A., Maulina, S., & Bruce, S. (2020). Secondary school mathematics teachers' views on E-learning implementation barriers during the COVID-19 pandemic: The case of Indonesia. *Eurasia Journal of Mathematics, Science and Technology Education*, 16\*(7). <https://doi.org/10.29333/EJMSTE/8240>
- Maatuk, A. M., Elberkawi, E. K., Aljawarneh, S., Rashaideh, H., & Alharbi, H. (2021). The COVID-19 pandemic and E-learning: Challenges and opportunities from the perspective of students and instructors. *Journal of Computing in Higher Education*, 1-18\*.
- Moreno-Guerrero, A.-J., Aznar-Díaz, I., Cáceres-Reche, P., & Alonso-García, S. (2020). E-learning in the teaching of mathematics: An educational experience in adult high school. *Mathematics*, 8\*, 840. <https://www.researchgate.net/publication/341620736>

- Naemah Abdul Wahab, Jamal Othman, Rozita Kadar, & Saiful Nizam Warris. (2022). Online learning modes: Synchronous and asynchronous. Jabatan Sains Komputer & Matematik (JSKM), UITM Cawangan Pulau Pinang. e-ISBN : 978-967-25608-3-8
- Nora Mahpar. (2021). Students losing interest in online lessons, attendance dropping, says expert. Retrieved from <https://www.freemalaysiatoday.com/category/nation/2021/06/19/students-losing-interest-in-online-lessons-attendance-dropping-says-expert/>
- Paules, C. I., Marston, H. D., & Fauci, A. S. (2020). Coronavirus infections – More than just the common cold. \*Jama, 323\*(8), 707–708. <https://doi.org/10.1001/jama.2020.0757>
- Reyes-Chua, E., Sibbaluca, B. G., Miranda, R. D., Palmario, G. B., Moreno, R. P., & Solon, J. P. (2020). The status of the implementation of the E-learning classroom in selected higher education institutions in Region IV-A amidst the Covid-19 crisis. \*Journal of Critical Reviews, 7\*, 253–258. <https://link.springer.com/article/10.1007%2Fs10639-020-10219-y>
- Samir, M., El-Seoud, A., Taj-Eddin, I. A. T. F., Seddiek, N., El-Khouly, M. M., & Nosseir, A. (2014). E-learning and students' motivation: A research study on the effect of E-learning on higher education. \*International Journal of Emerging Technologies in Learning, 9\*(4

**ALAM'S RATINGS' PERCEPTIONS OF AUTONOMOUS SHIPS**

Amir Syawal Bin Kamis  
amirsyawal@alam.edu.my

*Rating Programs, Akademi Laut Malaysia, BT 30 Kg Tg Dahan, 78200 Kuala Sungai Baru  
Melaka, Malaysia*

**ABSTRACT**

The development of autonomous ships has been a popular topic in the maritime industry, particularly after the recent maritime autonomous surface ships exercise conducted by International Maritime Organisation. It has huge potential to revolutionise ship navigation at sea. This study seeks to investigate the views of undergraduate rating students from Akademi Laut Malaysia regarding autonomous ships. The research involved interviewing the rating students and analysing the data with Atlas-ti software. Results indicate that rating students are typically in agreement that autonomous ships' concept can improve safety aboard manned vessels. They recognise that technology has the potential to enhance operational efficacy and reduce human error. However, the students were concerned about the potential impact of autonomous ships on industry-wide job security. They are concerned that the implementation of autonomous ships will reduce the number of seafarers required on ships. This document offers valuable insights into the perspectives of seafarers regarding autonomous ships, which can inform the development and implementation of this technology within the maritime industry. By resolving the concerns of seafarers, industry stakeholders can facilitate the adoption of autonomous ships in a more harmonious manner.

**ARTICLE INFO**

*Keywords:*  
*Autonomous  
ship,  
Perception,  
Qualitative,  
Seafarer,  
Thematic  
analysis*

**1.0 INTRODUCTION**

The implementation of autonomous ships is anticipated to bring about a significant transformation in the maritime sector. Advancements in autonomous navigation systems and machine learning algorithms have increased the probability of achieving fully autonomous ships, as per recent research (Ayob et al., 2020). Autonomous shipping has garnered considerable attention in recent years as a growing number of scholars have directed their research towards the advancement of sophisticated technologies that can enable the functioning of unmanned vessels, including mathematical models and algorithms (Ayob et al., 2020; Fan et al., 2020; Jeong et al., 2019; Kamis & Fuad, 2022). Consequently, a plethora of research

studies have surfaced, demonstrating an increasing inclination towards investigating this domain. The prospective advantages of self-governing shipping are noteworthy, encompassing diminished operational expenses, enhanced safety, and heightened efficacy. The feasibility and practicality of autonomous ships are increasing due to the advancements in machine learning, artificial intelligence, and robotics. Consequently, it is probable that the research in this domain will persist in expanding as scientists and engineers endeavour to tackle the technical and regulatory obstacles that are yet to be overcome.

The International Maritime Organisation (IMO) carried out an assessment of the feasibility of autonomous vessels in practical settings through a maritime autonomous surface ships (MASS) exercise in 2018, which was deemed successful (IMO, 2021). The aforementioned activity has generated significant discernments regarding the prospective advantages and hindrances of utilising autonomous surface ships in business endeavours. Various corporations, such as Rolls-Royce and IBM, have initiated research and development activities in the domain of autonomous shipping and have achieved significant advancements in the development of autonomous ship technology (IBM, 2022; Rolls-Royce, 2016). The Norwegian container ship, MV Yara Birkeland, is expected to initiate its operations soon and is currently the vessel that is closest to achieving complete autonomy. The advent of this novel zero-emission vessel will inaugurate a fresh epoch for worldwide marine transportation and facilitate the attainment of the sustainability objectives established by the United Nations (Skredderberget, 2023). Autonomous ships have the capability to enhance safety, efficiency, and environmental sustainability, thereby presenting a potential revolution in the maritime sector in the coming years (Lazarowska, 2019).

## **2.0 OBJECTIVE OF THE STUDY**

The introduction of autonomous ships has been hailed as a significant step forward for the shipping industry since it has the potential to improve the safety of vessels, save operating expenses and reduce carbon emissions. This reach intends to investigate ALAM's ratings' perception of the autonomous ship.

## **3.0 METHODOLOGY**

The first stage of the study is to briefly introduce to the students the concept of autonomous ships through a lecture session, as shown in Figure 1. A group of 75 students were given an explanation of the concept of an autonomous ship during this phase. This session is expected to stimulate the interest of students and prompt them to generate inquiries that will shape their perceptions of autonomous ships (Alvarado et al., 2011).

During the second stage, a sample of ten students was selected randomly and subsequently interviewed to evaluate their comprehension of the autonomous ship's concept and their attitudes towards autonomous vessels (Boyce & Neale, 2006). The interview inquiries will evaluate the student's comprehension, their viewpoints on the advantages and disadvantages of autonomous ships, their insights on the challenges and limitations of autonomous ships, and their perceptions regarding the factors that contribute to the development of autonomous ships.

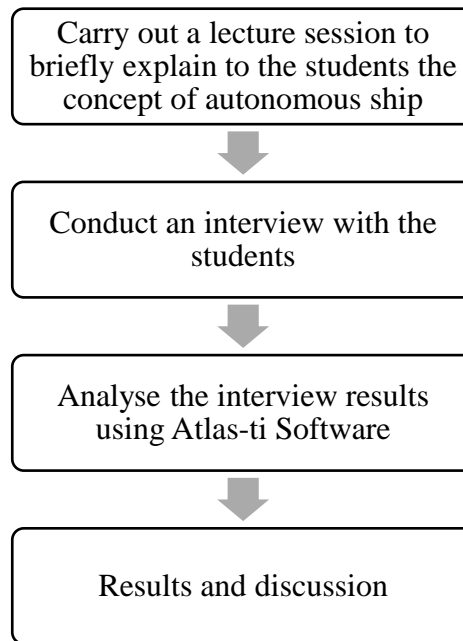

Figure 1. The research flow

Afterwards, using the Atlas-ti programme, the interview data were analysed thematically. The software will be used to categorise the data and identify the themes that emerged most prominently from the interviews. The themes will be analysed and interpreted so as to draw conclusions (Nowell et al., 2017). The study's findings will be presented as a summary of the main themes that emerged from the interviews, as well as an analysis and interpretation of the data. In addition to discussing the implications of the findings, the report should presumably reveal opportunities for future research.

#### 4.0 FINDINGS AND DISCUSSION

The participants in this study are male students enrolled in the pre-sea rating programme at Akademi Laut Malaysia, all of whom are between the ages of 20 and 25. Furthermore, it is noteworthy to mention that those mentioned above lack any antecedent familiarity with sailing on a vessel. The relevance of this information is contingent upon the contextual parameters of the survey or study being undertaken. It can be deduced that the participants are presently undergoing seafarer training based on the fact that they are enrolled in a pre-sea rating programme. The data pertaining to the user's gender, age, and level of experience can be utilised to understand their viewpoints, beliefs, and attitude concerning the maritime industry and the obstacles encountered by novices in this domain. The followings are the interview questions that were asked during the interview:

1. How familiar are you with the concept of autonomous vessels?
2. What are the potential benefits of autonomous ship operation, in your perspective?
3. What are the drawbacks of autonomous ship operation, according to your perspective?
4. What is your perspective on the potential effects of autonomous vessels on the workforce within the maritime industry?
5. What are the challenges and limitations associated with autonomous ship operation, according to your perspective?
6. What factors do you believe are responsible for the implementation of autonomous ships?

## KNOWLEDGE OF AUTONOMOUS SHIP

As a result of the interview, it was revealed that two of the students claimed to possess a firm understanding of the concept of autonomous vessels. They were able to provide insightful elucidations regarding the functioning of autonomous vessels, the benefits and drawbacks of the technology, and the potential uses for the vessels. Despite possessing a fundamental understanding of the operational mechanisms and significance of autonomous vessels, the remaining eighth of students expressed a need for supplementary resources to attain a comprehensive grasp of the concept.

The results suggest that certain students may possess a firm grasp of the concept of autonomous vessels; however, there is a necessity for enhanced education and awareness regarding this developing technology to ensure that all students comprehensively comprehend the subject matter.

## THE BENEFITS OF HAVING AUTONOMOUS SHIP

### Safety

The study revealed that a significant proportion of the student population held the belief that the foremost objective of autonomous ships was to enhance safety. The proponents of autonomous ships posit that such vessels have the potential to mitigate the hazards linked to human fallibility in navigation, consequently diminishing the probability of maritime mishaps and fatalities. Apart from safety, a number of students opined that the reduction of workforce and manpower on ships was a noteworthy advantage of autonomous vessels. It was perceived that a reduction in the quantity of crew members present on ships would result in economic benefits for shipping enterprises. According to some fellow students, the preservation of uniformity in vessel navigation and motion was deemed a crucial benefit of self-governing ships.

### Reduce human error

The students opined that the implementation of autonomous vessels could guarantee adherence to pre-established routes and consistent velocity, thereby mitigating the variability in the ship's motion. In addition, a number of them held the belief that the implementation of autonomous vessels could potentially mitigate instances of human error in navigation, thereby diminishing the likelihood of accidents stemming from such errors. The implementation of sophisticated technology in ship navigation could potentially reduce the occurrence of errors attributable to human operators.

In general, the students expressed diverse perspectives regarding the principal advantages of autonomous vessels, with safety and cost minimisation emerging as the prevailing topics. It is noteworthy that the benefits exhibit interdependence, given that mitigating the likelihood of mishaps can result in decreased expenses for entities engaged in maritime transportation. The viewpoints of the students regarding the advantages of autonomous vessels underscore the potential benefits of this nascent technology and the necessity for additional instruction and comprehension of the subject matter.

## PRIMARY DOWNSIDE OF AUTONOMOUS SHIP

### System Malfunctions

The participants were requested to offer their perspectives regarding the limitations of autonomous vessels. Several students have conveyed apprehension regarding the potential for system malfunction in self-governing vessels, which may result in catastrophic consequences. In addition, the students conjectured that in the event of an autonomous vessel operating amidst manned vessels, the possibility of accidents could not be ruled out due to the potential lack of complete understanding of collision regulations by the autonomous vessel, as well as the likelihood of non-compliance by certain navigators. Furthermore, certain students have highlighted that while operating a semi-autonomous vessel, wherein humans retain partial control, there exists a potential hazard of navigators excessively depending on the system, thereby elevating the probability of an incident. The possibility of system failure is considered to be a potential disadvantage of autonomous ships.

Despite the utilisation of sophisticated technology in these vessels, the possibility of malfunctions or technical complications that may result in catastrophic outcomes remains a concern. In the event of a system malfunction, an autonomous vessel may encounter a loss of navigational control, thereby jeopardising the safety of both the crew and the ship. The potential occurrence of accidents during the co-navigation of autonomous and manned vessels has been identified as a concern by the students. Although autonomous vessels may comply with collision regulations, they may not possess a complete comprehension of the manoeuvres executed by human navigators, who may not conform to identical regulations. Insufficient understanding could result in unforeseen collisions or perilous circumstances, despite the autonomous vessel's adherence to protocol.

### Over-reliance on technology

Additionally, the excessive dependence on the system within a semi-autonomous vessel represents a possible disadvantage of this technological innovation. Over-reliance on a vessel's autonomous functionalities by navigators could potentially result in the disregard of crucial data or inadequate response to unanticipated circumstances. The excessive dependence on navigation systems may lead to incidents that could have been prevented had the navigators exercised greater attentiveness. In summary, it is crucial to consider and mitigate the limitations of self-governing vessels, as emphasised by scholars, in light of technological advancements. As the frequency of these vessels increases, it is crucial to address the potential hazards associated with their utilisation and establish adequate safety protocols to avert mishaps and guarantee the well-being of crew members and other vessels in the proximity.

## THE IMPACT ON MARITIME EMPLOYMENT

### Reduce job security onboard ship

The findings of the interview suggest that a considerable proportion of the students hold the view that the advent of autonomous vessels would have an adverse impact on the opportunities for maritime labour. The participants conveyed apprehension regarding the prospective instability of their employment, particularly in light of the uncertain trajectory of the future. The deployment of autonomous ships may lead to a potential decrease in the demand for seafarers to operate the vessels.



## Increase jobs in other areas

Notwithstanding, certain students hold the viewpoint that the implementation of novel technologies such as artificial intelligence and software engineering, which are imperative for the operation of autonomous vessels, may give rise to novel job prospects. From their perspective, the issue at hand pertains to the willingness to engage in the exploration of novel prospects and undertaking measured risks. In general, the outcomes of the interview indicate a notable level of ambiguity and apprehension among students concerning the probable influence of autonomous vessels on maritime labour. While a portion of students express optimism regarding the potential for emerging technological fields to generate employment opportunities, a larger proportion harbour apprehensions regarding the possibility of job displacement.

The potential impact of autonomous ships on the maritime industry is yet to be determined. However, it is evident that these matters will require vigilant observation and resolution in the forthcoming years. The findings underscore the significance of furnishing seafarers with pertinent educational and training prospects, which can equip them for potential employment prospects that may surface with the advent of autonomous vessels. Providing seafarers with adequate knowledge and skills in emerging fields such as artificial intelligence and software development is imperative, as it has the potential to generate novel employment prospects. Through this approach, maritime professionals can enhance their competitiveness in the labour market and explore alternative career trajectories congruent with their aptitudes and passions. The provision of educational resources and training opportunities can aid in maintaining the preparedness of seafarers for the evolving employment landscape within the maritime sector.

## CHALLENGE AND LIMITATION

### Safety and Security

The students' prioritisation of implementing suitable measures to tackle potential safety and security concerns is indicative of their conscientious approach towards the integration of autonomous technology within the maritime sector. Although the idea of enhanced efficacy and decreased expenses linked with automation may appear alluring, the potential hazards associated with this novel technology must not be disregarded. An area of significant interest pertains to the upkeep of self-governing vessels, which may necessitate an alternative methodology compared to the conventional approach adopted for crewed ships.

### Ship maintenance

The students express a keen interest in delving deeper into the operational procedures of these vessels, particularly with regard to conventional techniques for corrosion prevention, such as chipping and painting, as well as the replacement of lubricants and spare parts. Inadequate maintenance of autonomous vessels may lead to compromised operational safety, thereby posing a risk to the security of both the vessel and its cargo. The students also highlight the significance of addressing cyber security threats as a crucial matter. With the growing dependence of the maritime sector on technology, it is also exposed to heightened susceptibility to cyber threats. The possibility exists for hackers to gain unauthorised access to an autonomous vessel, thereby jeopardising the safety of the ship, cargo, and surrounding ecosystem. Hence, it is imperative to implement measures aimed at safeguarding these vessels from potential cyber threats. In summary, the student posits that prudence is necessary, although the potential for self-governing technology in the maritime sector appears encouraging.

Additional investigation and advancement are imperative to guarantee the safe and secure management of these systems. The maritime industry can optimise the benefits of autonomous technology while ensuring the safety of human lives and cargo by addressing maintenance and cyber security concerns. In the end, this will enable the industry to attain the advantages of automation while upholding a conscientious stance towards technological advancement.

### THE FACTORS THAT TRIGGER THE DEVELOPMENT OF AUTONOMOUS SHIPS.

#### Influence by unmanned road vehicle

The students suggest that the autonomous vessel was potentially influenced by the development of autonomous automobiles and other self-driving modes of transportation, and their assertion holds some degree of validity. The principal objective of autonomous vehicles is to diminish the human labour force and enhance efficacy. Autonomous vehicles are engineered to function without human intervention, thereby diminishing the necessity of humans for navigation operations.

#### Influence by green shipping concept

Notwithstanding, certain students contend that the autonomous vessel was devised to address ecological concerns. The MV Yara Birkland is cited as an instance of an autonomous vessel specifically engineered to mitigate carbon emissions. The implementation of carbon reduction strategies, including but not limited to optimisation, electrification, and decarbonisation, is imperative in order to effectively alleviate the consequences of climate change. The implementation of batteries in the MV Yara Birkland aligns with a key objective of the decarbonisation strategy, namely the transition towards electric power as a primary energy source. Electricity can be produced using renewable sources such as solar, wind turbines, and hydroelectric plants, which are considered more ecologically sustainable than diesel engines that release harmful emissions such as carbon dioxide.

#### Ship owners looking for methods to increase cargo capacity

An additional benefit of minimising the human presence on board is the expansion of the cargo transportation capability. The removal of the structure necessary for human habitation on a vessel can result in a decrease in displacement and an increase in the cargo capacity of said vessel. The decrease in human presence aboard the vessel leads to the elimination of necessary resources such as sustenance, hydration, and medical aid, resulting in an additional reduction in weight.

In summary, the perspectives of students regarding autonomous vessels are characterised by a dichotomy between the reduction of human labour and the resolution of environmental concerns. Autonomous vessels were originally conceived with the aim of minimising human labour; however, the technology is presently advancing to integrate eco-friendly characteristics. The MV Yara Birkland exemplifies an autonomous vessel that integrates both components. The adoption of electric energy sources and the minimisation of human presence aboard vessels are crucial determinants in mitigating carbon emissions and augmenting cargo transportation capability.

## 5.0 CONCLUSIONS

It is noteworthy to emphasise that the participants in this study were students of the rating programme who lacked any prior experience in working aboard a ship. Hence, it can be predicted that their perceptions are constrained by their comprehension of in-class learning. The study demonstrated while some students possessed a good comprehension of the notion of autonomous vessels, the remaining students conveyed a requirement for additional educational materials.

To them, autonomous ships offer several advantages, such as enhanced safety, decreased reliance on human force, and maintenance of consistency in vessel navigation and movement. Advocates of autonomous ships argue that these types of vessels possess the capability to alleviate risks associated with human error in navigation. The advantages of autonomous vessels, including safety and cost minimisation, were observed to elicit diverse perspectives among the students. Notwithstanding, the individuals also conveyed concerns with respect to the possibility of a system malfunction in autonomous vessels, as well as the potential dangers of navigators excessively relying on the system.

The possibility of system failure is regarded as a potential drawback of autonomous vessels. The possibility of malfunctions or technical complications in autonomous vessels continues to be a matter of concern. Furthermore, an overreliance on the semi-autonomous vessel's system may result in preventable incidents if the navigators had exercised more attentiveness. In view of technological advancements, it is imperative to address and alleviate the constraints of autonomous vessels while implementing sufficient safety measures to prevent accidents and ensure the safety of crew members and nearby vessels. The results of the interview revealed that there exists a certain degree of uncertainty and unease among students with regard to the potential impact of autonomous vessels on the maritime workforce.

While a certain segment of the population holds a positive outlook, a greater proportion maintains concerns regarding the potential for job displacement. The results emphasise the significance of providing relevant educational and training opportunities to seafarers in order to prepare them for potential employment opportunities. The conscientious approach of students towards the integration of autonomous technology within the maritime sector is reflected in their prioritisation of implementing appropriate measures to address potential safety and security concerns. The student posits that the advancement of autonomous automobiles and other self-driving transportation modalities potentially impacted the emergence of autonomous ships. The primary aim of autonomous vehicles is to reduce the need for human labour and improve efficiency, as they are designed to operate without human intervention.

The implementation of this approach would allow the industry to leverage the benefits of automation while maintaining a responsible attitude towards technological progress. The MV Yara Birkland represents a paradigmatic instance of an autonomous watercraft that has been meticulously designed to address the issue of carbon emissions reduction. The effective mitigation of the impacts of climate change necessitates the adoption of carbon reduction strategies, including but not limited to optimisation, electrification, and decarbonisation. Furthermore, the reduction of human presence on board has the potential to enhance cargo transportation capacity and decrease overall weight. The original purpose of autonomous vessels was to reduce human labour; however, recent technological advancements have enabled the integration of environmentally sustainable features.

## REFERENCES

- Alvarado, S., Kanter-Braem, B., Manz, K., Masciopinto, P., McKenna, E., Nelson, D., Williams, C., & Korek, K. (2011). Sensation and perception: a unit lesson plan for high school psychology teachers. *National Standards for High School Psychology Curricula*, 1–46. <https://www.apa.org/ed/precollege/topss/lessons/sensation.pdf>
- Ayob, A. F., Jalal, N. I., Hassri, M. H., Rahman, S. A., & Jamaludin, S. (2020). Neuroevolutionary autonomous surface vehicle simulation in restricted waters. *TransNav*, 14(4), 865–873. <https://doi.org/10.12716/1001.14.04.11>
- Boyce, C., & Neale, P. (2006). CONDUCTING IN-DEPTH INTERVIEWS: A Guide for Designing and Conducting Interviews for Evaluation Input. PATHFINDER International Tool Series, Monitoring and Evaluation-2, May 2006. *Attachment and Human Development*, May 2–12.
- Fan, C., Wróbel, K., Montewka, J., Gil, M., Wan, C., & Zhang, D. (2020). A framework to identify factors influencing navigational risk for Maritime Autonomous Surface Ships. *Ocean Engineering*, 202(February). <https://doi.org/10.1016/j.oceaneng.2020.107188>
- IBM. (2022). *AI-Powered Automation - Mayflower Autonomous Ship*. <https://www.ibm.com/cloud/automation/mayflower-autonomous-ship>
- IMO. (2021). *Outcome of the Regulatory Scoping Exercise for the Use of Maritime Autonomous Surface Ships (Mass)*. MSC.1/Circ.1638. [https://www.wcdn.imo.org/localresources/en/MediaCentre/PressBriefings/Documents/MSC.1-Circ.1638 - Outcome Of The Regulatory Scoping Exercise For The Use Of Maritime Autonomous Surface Ships... \(Secretariat\).pdf](https://www.wcdn.imo.org/localresources/en/MediaCentre/PressBriefings/Documents/MSC.1-Circ.1638 - Outcome Of The Regulatory Scoping Exercise For The Use Of Maritime Autonomous Surface Ships... (Secretariat).pdf)
- Jeong, M. G., Lee, E. B., Lee, M., & Jung, J. Y. (2019). Multi-criteria route planning with risk contour map for smart navigation. *Ocean Engineering*, 172(August 2018), 72–85. <https://doi.org/10.1016/j.oceaneng.2018.11.050>
- Kamis, A. S., & Fuad, A. F. A. (2022). *A Comparison Study between Advance Transfer Technique and Advance Transfer Mathematical Model Using Bulk Carrier Ship: Cross-track Distance Validation by Percentage Change and Mann Whitney U Test*. 16(3), 541–551. <https://doi.org/10.12716/1001.16.03.17>
- Lazarowska, A. (2019). Research on algorithms for autonomous navigation of ships. *WMU Journal of Maritime Affairs*, 18(2), 341–358. <https://doi.org/10.1007/s13437-019-00172-0>
- Nowell, L. S., Norris, J. M., White, D. E., & Moules, N. J. (2017). Thematic Analysis: Striving to Meet the Trustworthiness Criteria. *International Journal of Qualitative Methods*, 16(1), 1–13. <https://doi.org/10.1177/1609406917733847>
- Rolls-Royce. (2016). *Autonomous Ships: The Next Step*. Marine Ship Intelligence. <https://www.rolls-royce.com/~media/Files/R/Rolls-Royce/documents/customers/marine/ship-intel/rr-ship-intel-aawa-8pg.pdf>
- Skredderberget, A. (2023). *Yara Birkeland: The first zero-emission, autonomous ship*. <https://www.yara.com/knowledge-grows/game-changer-for-the-environment/>

---

## CONSTRUCTIVISM LEARNING THEORY APPLICATIONS IN MARITIME ENGINE-ROOM SIMULATOR (ERS) AND 21ST CENTURY CLASSROOM

Zaful Rullah Hakiem Bin Zaini  
[zaful.rullah@alam.edu.my](mailto:zaful.rullah@alam.edu.my)

*Centre for Professional Training (Simulator), Akademi Laut Malaysia, BT 30 Kg Tg Dahan, 78200 Kuala Sungai Baru Melaka, Malaysia*

---

### ABSTRACT

This study explores the benefits of good knowledge of learning theories for educators to understand the learning process and ensure effective and efficient learning. Specifically, it focuses on the constructivist learning theory, which emphasises that knowledge cannot be transferred but should be built by learners. Using extensive literature reviews, the study formulates applications of Constructivism in maritime Engine-Room simulator learning activity, allowing learners to be more engaged and actively involved in the learning process. Overall, the study emphasises the importance of constructivist learning theory and its various applications in the 21st-century classroom to ensure effective and efficient learning.

### ARTICLE INFO

*Keywords:*  
*Learning theories, Constructivism, 21st-century classroom, Maritime education and training, Engine room simulator*

---

### 1.0 INTRODUCTION

"Educational psychology, as a field of study, is devoted to the application of a wide variety of theories to understand the way humans learn so that the most effective practices of instruction can be implemented." (Click et al., 2022)

Learning theory is one of the aspects of educational psychology. Four dominant learning theories are famous among scholars: behaviourism, cognitivism, Constructivism and connectivism. This study will discuss the definition and overview and include an example of applying Constructivism learning theory using an Engine-Room simulator (ERS).

### 2.0 LITERATURE REVIEW

Constructivism can be divided into two dominant theories: Cognitive Constructivism by Jean Piaget and Social Constructivism by Lev Vygotsky (Figure 1). In Cognitive Constructivism, Piaget believes that the learner constructs knowledge based on prior knowledge and experience (Piaget, 1958). Although Vygotsky acknowledges that cognition results from mental construction, as stated by Piaget, Vygotsky says that other external factors may influence the construction of knowledge. In social cognitivism, Vygotsky believes knowledge is constructed in a social context through active process and collaboration (Vygotsky et al., 1978).

The teacher is the one who sets what is to be taught. Hence, behaviourism and cognitivism learning theories have systematic approaches and are typically more teacher-centred. The strategy is different under Constructivism learning theory, which emphasises student-centred learning more. The teacher plays a more passive role and merely acts as a facilitator to speed up learning if necessary. As shown in Figure 1, some examples of applications for Constructivism learning theory are flipped classrooms, role-play, and simulation. Improving the learning process also depends on outside variables and socialisation with other students. This process of autonomous or collaborative learning is also known as situated learning.

The Zone of Proximal Development (ZPD) (Figure 2), frequently employed in social Constructivism theory, states that the trainer must understand when it is appropriate to remove assistance from the learners to maximise learning outside their comfort zones. Incremental learning is the best kind of learning. The instructor must watch out that the students don't lose interest in the content or think it's too difficult because of the lack of assistance.

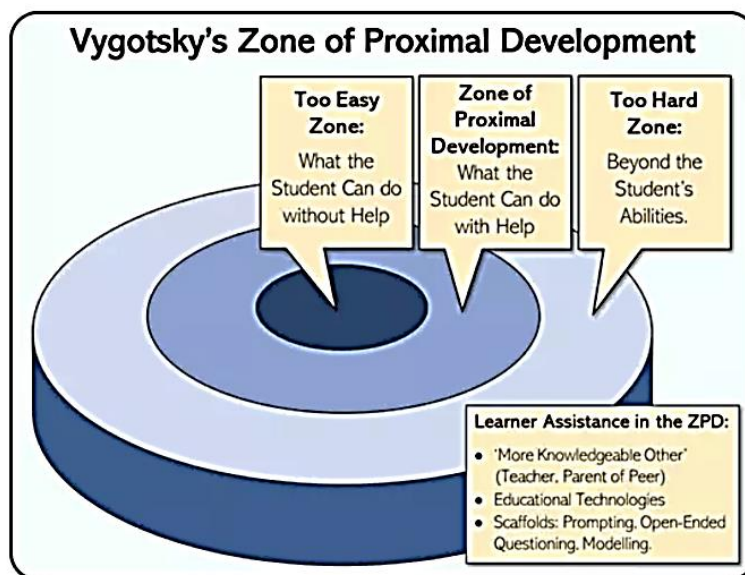

Figure 2: Zone of Proximal Development.

Note: Reproduced from Sociocultural theory of learning in the classroom by HelpfulProfessor, n.d. Retrieved from <https://helpfulprofessor.com/sociocultural-theory-education/>

The Constructivism technique takes longer than behaviourism and cognitivism since it requires students to engage in self-regulated learning (SRL) and generate knowledge. It also requires more tedious preparation and good learning facilities, which subsequently would increase the cost of education. The earlier approaches are more rule-based and objectivist, and the teachers have complete control over their lessons. However, scholars claim that Constructivism is the ideal strategy for maximising student potential, encouraging critical thinking, and being a dynamic learning process (Padirayon et al., 2019).

## 2.1 Overview of Constructivism

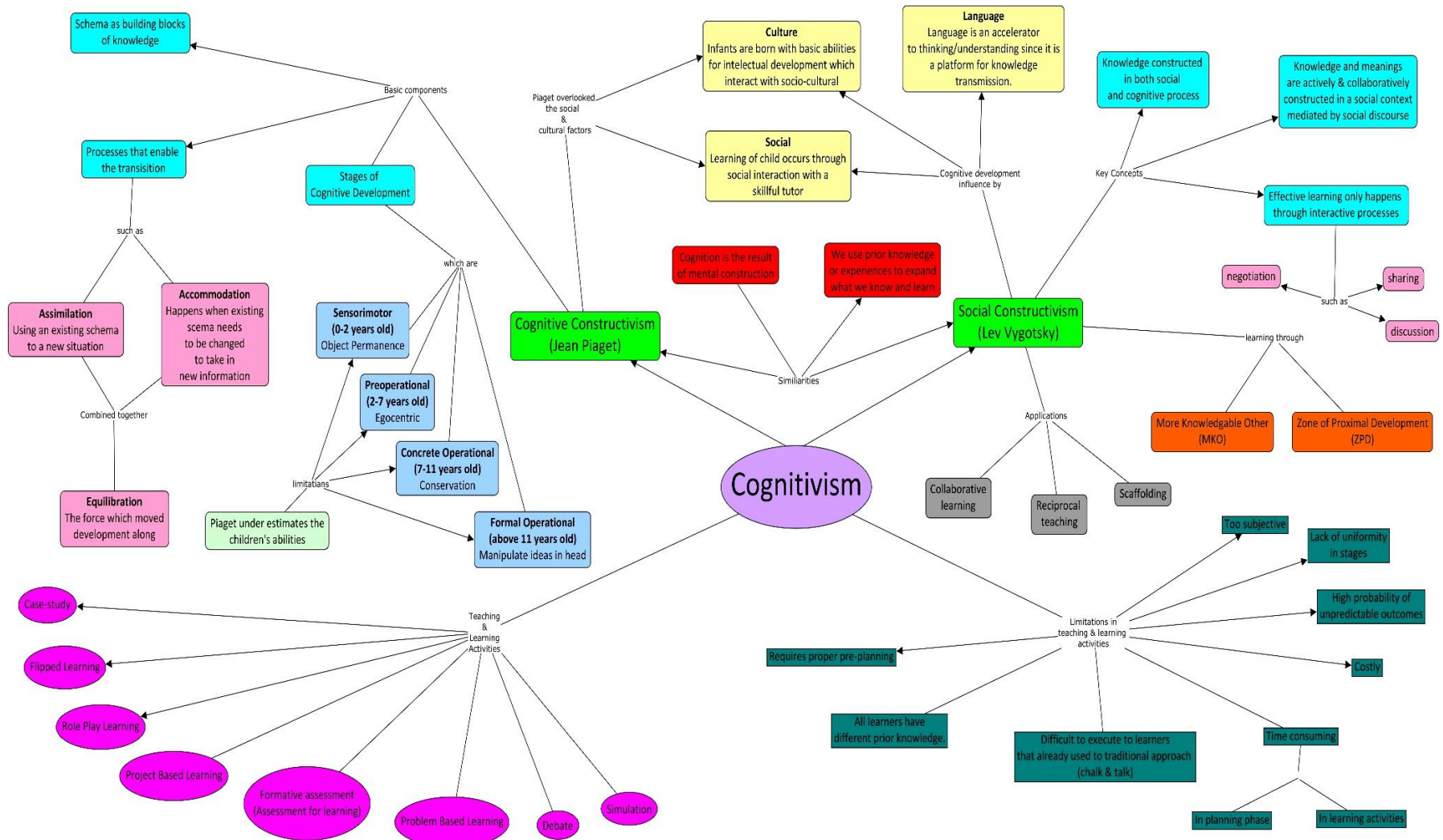

Figure 1: General overview of Constructivism Learning Theory  
 Note: Self-produced from variable sources

## 2.2 Constructivism in the 21<sup>st</sup>-Century Classroom

People with 21st-century skills may evolve with the times. Hence, educators must ensure the learners are equipped to acquire this skill set. To use the Constructivism approach in the 21<sup>st</sup>-century classroom, teachers should consider several factors to provide an effective learning process. Competencies like critical thinking and the capacity to communicate with people from various languages and cultural backgrounds are needed in today's labour market and benefit learners (Chiruguru, 2020).

In traditional teaching, learning occurs when a teacher transfers their knowledge to the learners. Since the constructivist approach differs, a teacher should be prepared to embark on this journey. The teacher is a facilitator during students' independent work by offering guidance, tailoring the assignments to each student's unique skills, fostering a welcoming environment in the classroom that encourages participation, and stimulating each student's curiosity. As each learner may have different prior knowledge, the teacher must be able to closely monitor learners' performance through their verbal feedback, body language and behaviour. The student-centred approach is aligned with Constructivism and the 21<sup>st</sup>-century classroom setting. However, based on a study in Ukraine reveals that most academic staff members in Ukraine had a difficult time distinguishing between the traditional teacher's function and that of a facilitator, moderator, or tutor in student-centred learning (Bulvinska & Chervona, 2019). In contrast, one study in Malaysia highlights a positive relationship between teachers' motivation and adopting 21<sup>st</sup>-century skills in the classroom (Hoon et al., 2022). Another study worth discussing is the teacher's perception of teaching in the 21<sup>st</sup>-century classroom.

*"... when teachers possess positive perceptions about their proficiencies in 21<sup>st</sup>-century skills, they may provide a constructivist learning environment by helping their students arrange their learning, discuss their personal opinions and criticise the teaching styles or strategies used by their teachers." (Anagün, 2018).*

These studies show that Constructivism is only suitable for some situations. One of the essential factors is the teacher itself, which is influenced by their readiness, motivation and perception. In ensuring the Constructivism approach is effective, a teacher requires good communication skills and creativity to develop the learning activities and should be adaptive and dynamic to any changes in the learning process.

Organisation and management for the 21<sup>st</sup>-century classroom is another crucial factor in ensuring learning takes place effectively through Constructivism, for instance, by having a democratic classroom environment. A constructivist teacher sets up the classroom so the instructor and students can shape the environment rather than blatantly controlling the learners. All decisions made in the classroom impact them as individuals and as learners. A teacher plays a significant role in ensuring this thing happens. As a result, the learners become more expressive, which may help them to verbalise their thought in diplomacy, improve their communication skills, collaborate well with colleagues, and gain confidence in decision-making. All these aspects are essential to acquire 21<sup>st</sup>-century skills and ensuring the Constructivism approach is effective.

Digital literacy is another critical component in 21st-century classrooms (Figure 3). Therefore, the teacher should maximise the utilisation of technology in classroom management (Bates, 2015). This approach might be costly and impractical when the learning institution operates on a very tight budget. However, many service providers offer free educational software with decent functions and features, such as Google Classroom, Moodle, Kaltura Video Cloud and OpenEduCat (G2, 2022). Since the options are abundant, the teacher should be selective and has a good technology adaptation. The study in Indonesia shows that technology adaptation is



a mediating factor for psychological capital, which subsequently affects classroom performance (Wisetsri et al., 2022). The teacher should be creative in utilising the technology as well. For instance, the teacher may ask the students to collaborate to develop the learning activity using open-source software. This will reduce a teacher's burden and simultaneously give the students a learning experience. In addition, this practice will help both teachers and learners with the new technology, which is increasing. However, the teacher should give adequate support to ensure the task is doable and motivate the learners to complete the task.

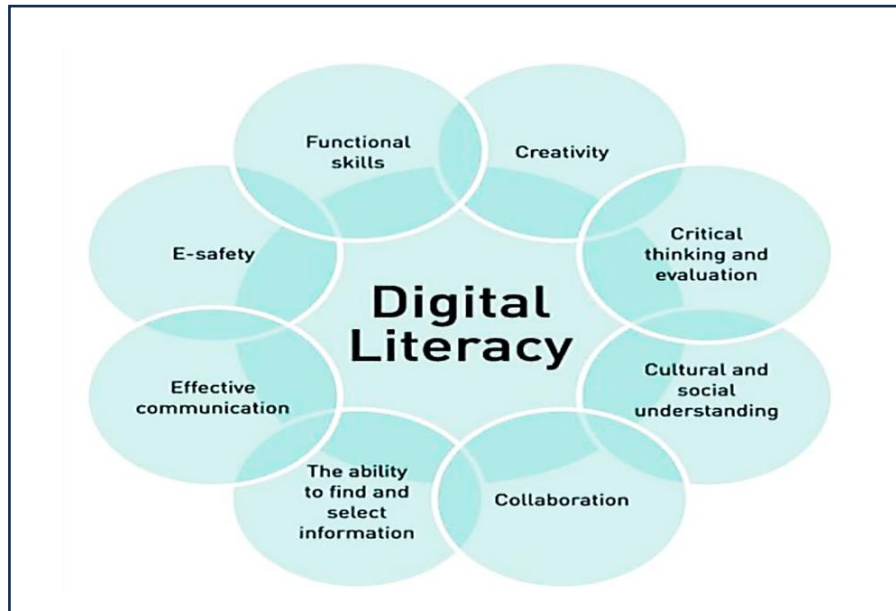

Figure 3: Scope of digital literacy.

Note: Reproduced from Digital Skills and Competencies in Schools by S.Cranmer, 2014.

### 3.0 METHODOLOGY

The purpose of this study is to investigate the application of Constructivism learning theory in the context of maritime Engine-Room simulator training and its incorporation into the classroom of the twenty-first century. Based on the findings, the researcher formulates an example of the application through ERS learning activities. This study relied primarily on literature reviews for data acquisition and analysis.

#### 3.1 Research Method

This study's research design is a literature review, which entails a systematic and exhaustive analysis of existing literature on applying Constructivism learning theory in maritime Engine-Room simulator training and the twenty-first-century classroom. The design of a literature review permits the accumulation, analysis, and synthesis of data from diverse sources of published literature.

#### 3.2 Data Gathering

This study's primary data acquisition method is a systematic review of the existing literature. The literature sources were identified through an exhaustive search of online databases. Search

terms included “Constructivism learning theory”, “Engine-Room simulator”, “21st-century classroom”, “maritime education”, “competency-based training”, “simulation-based learning”, “learner-centred approach”, and “active learning”. The inclusion and exclusion criteria were established to ensure that the study included only relevant literature.

### **3.3 Data Analysis:**

The compiled literature was analysed using thematic analysis, identifying the data’s themes, patterns, and trends. The thematic analysis consisted of reading and rereading the literature to identify key concepts, categories, and subcategories related to applying Constructivism learning theory in maritime Engine-Room simulator training and the 21st-century classroom. The identified themes were then synthesised to provide an overview of the Constructivism learning theory's application within the context of this study.

### **3.4 Ethical Implications:**

Since this study relied solely on literature reviews, there was no need for ethical considerations. The researcher ensured that all literature sources were appropriately cited and acknowledged to avoid plagiarism.

## **4.0 FINDINGS AND DISCUSSION**

Based on the findings from various literature and including the literature reviews from the previous chapter, the researcher has formulated the application of Constructivism in ERS classrooms. Figure 4 shows an example of a learning activity using a computer-based Engine-Room Simulator (ERS). The name of the training is Operation of Fresh Water Generator (FWG). In this practical training, the learners will use their prior knowledge to perform a starting operation of an FWG. This training is designed for marine engineering students who have never been on a ship.

Since the students don't have any field experience, the trainer needs to establish the knowledge to the students beforehand. This can be done by having extensive discussions about the equipment immediately before the exercise begins. Or else, it also could be covered in other theoretical classroom sessions.

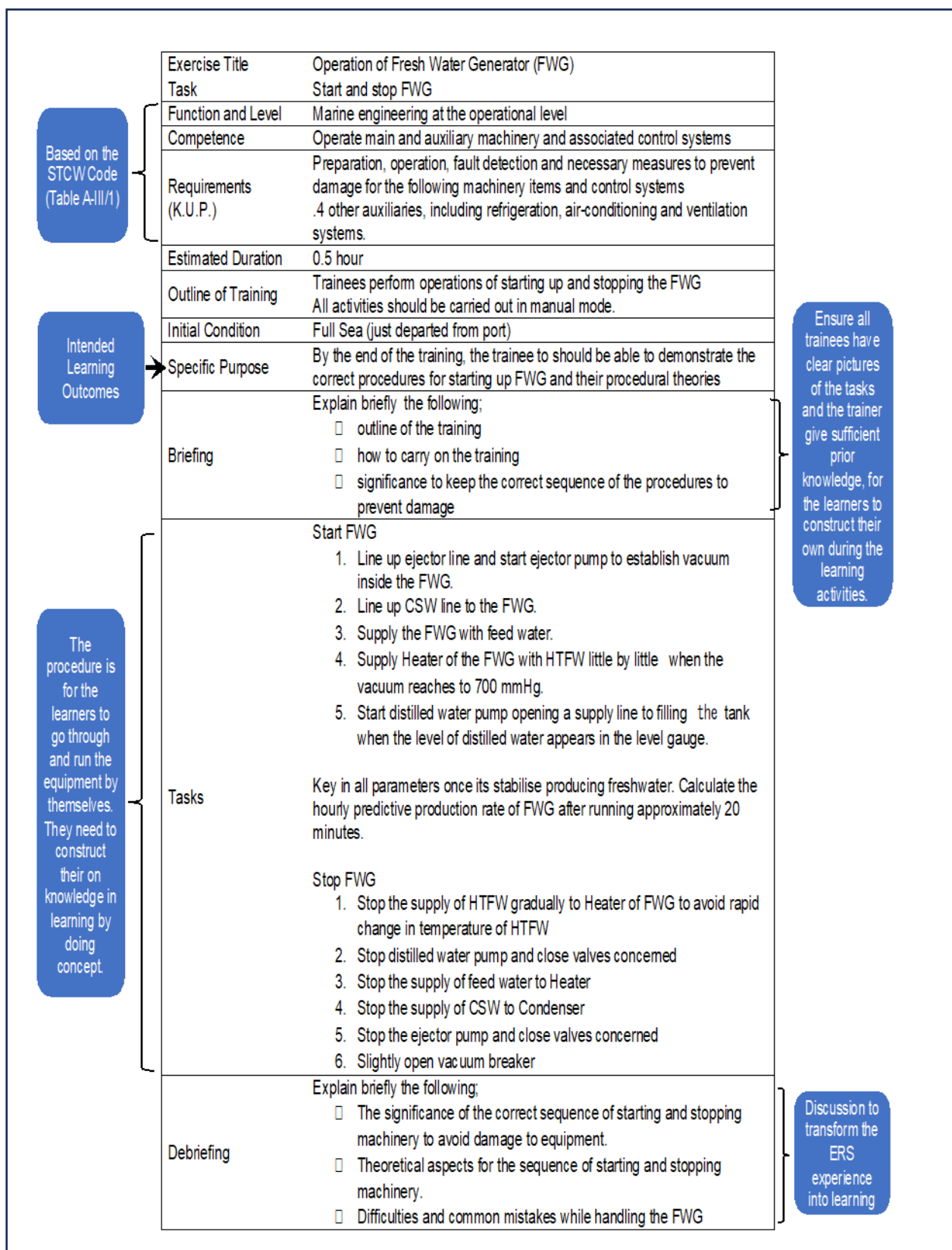

Figure 4: Lesson plan using Constructivism approach in Engine Room Simulator training  
Note: Adapted from Model course 2.07. Engine-Room simulator by International Maritime Organization, 2017, IMO Publication. Copyright 2017 by IMO Publication.

Nevertheless, the trainer should conduct a comprehensive briefing and introduction before the exercise can begin. The learners should clearly understand the specific learning objective and how to use the ERS. The trainer may use animation or real video from the ship to demonstrate the procedure from a different environment. This will help the learners to adapt the same concept in the ERS environment.

Each learner will be stationed in their respective workstation for the exercise. During the training, they should follow the procedures written in the exercise sheet. By doing it this way, the learners need to actively engage with the task so that they may complete the task. This is also known as the learning-by-doing method.

As the learners will learn by themselves, the trainer is known as a More Knowledgeable Other (MKO) in Constructivism. While the exercise runs, the trainer may visit each workstation to provide support or scaffolding. However, the intervention should be based on the ZPD. For instance, if a learner is stuck in the middle of an exercise, the trainer may ask some relevant questions to trigger the learner to reconsider their steps.

As the progression of all learners could not be the same, the trainer may assign the high-achiever learners to collaborate with the low-achiever learners to encourage collaborative learning.

Finally, is the debriefing session. Debriefing, self-reflection on the task and helping dispel all doubts should be the most crucial component of this activity. This procedure is dynamic because various classes could have different problems. The trainer may ask questions that help the learners to rationalise the experience into new knowledge. Peer assessment is another tool to verify the students' tasks and give learning experience for the students while assessing their colleagues. In addition, the trainer may conduct a fun formative assessment, such as Kahoot, to validate the learning activity's effectiveness and as a part assessment for learners' learning (Tan et al., 2018).

To summarise, this activity embeds Constructivism theory as the learners actively construct their knowledge through a learning-by-doing approach. The learning process only would be effective if the learners have pre-existing knowledge about the task, which could be done through lectures or demonstrations. Minimum intervention by the trainer also helps the learners to build their confidence and maximise the learning process. Although it is an active learning process, the trainer should monitor the progression and give necessary support or stimulus to help the learner in the learning process.

## **5.0 CONCLUSIONS**

Good knowledge of learning theories helps educators to understand the learning process to ensure learning takes place effectively and efficiently. In constructivist learning theory, knowledge cannot be transferred but should be built by the learners. Although this approach is costly, time-consuming and requires tedious planning, it is a potent tool in knowledge retention to develop critical thinking, collaboration and communication skills among the learners, which are essential 21st-century skills. The role of a teacher shifts from solely an instructor to a facilitator. To ensure the teacher does not burden the learners in constructing their knowledge, this has to be done based on ZPD in the concept of scaffolding. The applications of Constructivism allow the learners to be more engaged with the content and actively learn. Examples of non-exhaustive applications are flipped classrooms, debate, role-play, simulation and interactive classrooms. The teacher's readiness in terms of proficiency using this approach, classroom management and attitude towards the approach is crucial for 21st-century teachers. The teachers should maximise technology usage throughout the process to speed up the

technology adaptation for teachers and learners, which benefits the learning process and prepares the learners in their working field.

It is essential to recognise the study's limitations and the need for additional research to verify and validate the theoretical framework and findings presented in this study. This study is just a starting point for further research, which could involve conducting empirical research, such as experiments or surveys, to acquire data and test the theoretical hypotheses made in the study.

## REFERENCES

- Anagün, Ş S. (2018). Teachers' Perceptions about the Relationship between 21st Century Skills and Managing Constructivist Learning Environments. *International Journal of Instruction*, 11(4), 825-840. 10.12973/iji.2018.11452a
- Bates, A. W. (2015). *Teaching in a Digital Age*. Tony Bates Associates Ltd.
- Bulvinska, O., & Chervona, L. (2019). Transformation of the roles of Ukrainian Universities teachers in student-centred learning and teaching.3, 38-44. 10.28925/1609-8595.2019.3.3844
- Chiruguru, S. (2020). The Essential Skills of 21st Century Classroom (4Cs)10.13140/RG.2.2.36190.59201
- Click, K., Schwartz, N., & Bartel, A. (2022). *Educational Psychology: Learning and Instruction*. (pp. 1-35)10.1007/978-3-030-26248-8\_67-1
- G2. (2022). Top Free Classroom Management Software. <https://www.g2.com/categories/classroom-management/free>
- Hoon, T., Muthukrishnan, P., Koo, A. C., Kam, N., & Singh, P. (2022). Preservice Teachers' Motivation and Adoption of 21st-Century Skills., 205-218.
- Padirayon, L., Pagudpud, M., & Cruz, J. (2019). Exploring Constructivism learning theory using mobile game. *IOP Conference Series: Materials Science and Engineering*, 482, 012004. 10.1088/1757-899X/482/1/012004
- Piaget, J. & I., Brbel. (1958). *The Growth Of Logical Thinking From Childhood To Adolescence*. Routledge. 10.4324/9781315009674
- Tan, D., Ganapathy, M., & Mehar Singh, M. K. (2018). Kahoot! It: Gamification in Higher Education. *Pertanika Journal of Social Science and Humanities*, 26, 565-582.
- Vygotsky, L. S., Cole, M., John-Steiner, V., Scribner, S., & Souberman, E. (1978). *Mind in Society*. Harvard University Press.
- Wisetsri, W., Chuaytukpuan, T., Prompanyo, M., Raza, M., Cavaliere, L. P. L., & Akhtar, S. (2022). Impact of Psychological Capital and Technology Adaptation on Performance of Teachers.6, 8784-8793.

**NAVIGATING THE WATERS OF THE MARITIME INDUSTRY: CHALLENGES IN MALAYSIA**

Shahidah Binti Ahmad Suhaimi\*, Nadia Harnisa Binti Abdul Rahman, Zulkarnian Bin Ahmad, Chua Kim Muar, Ramesh Babu Amathalai, Nur Zulaikha Binti Samsudin, Aisyah Binti Othman, Ravinjit Singh A/L Pritam Singh

Shahidah.suhaimi@alam.edu.my\*, nadia.harnisa@alam.edu.my,  
zulkarnian.ahmad@alam.edu.my, chuakim@alam.edu.my,  
rameshb.amathalai@alam.edu.my, aisyah.othman@alam.edu.my,  
ravinjit.singh@alam.edu.my

Corresponding author\*

*Lecturer, Faculty of Business & Management, Akademi Laut Malaysia, BT 30 Kg Tg Dahan, 78200 Kuala Sungai Baru Melaka, Malaysia*

**ABSTRACT**

The maritime industry has always played a significant role in international trade and transportation. The industry has changed significantly in recent years as a result of the introduction of new technology and the expansion of globalization. In this conceptual paper, a review study is undertaken to identify the challenges that the Malaysian maritime industry is facing. In order to get the necessary data regarding the difficulties facing Malaysia's maritime industry, this study looked at two cases from journals. The two publications mentioned in the methodology were utilized to pinpoint the two primary issues the maritime industry in Malaysia is facing. Findings show there are two primary issues faced by maritime industry which are sustainability and cybersecurity. The result of the study is necessary for Malaysia's maritime industry to advance, and it can also be used to guide future research into other areas and industries.

**ARTICLE INFO**

*Keywords:*  
*Maritime*  
*Industry,*  
*Challenges,*  
*Sustainability,*  
*Cybersecurity,*  
*Shipping*

**1.0 INTRODUCTION**

Most economists agree that international trading makes the globe a better place to live. Due to the expansion of trade and globalization, the maritime industry has significantly increased during the past few decades which links nations and economies all over the world. Shipping, which satisfies around 90% of commercial demand, is very important to world trade (Zaman et.al, 2017). A sophisticated interconnected set of nodes make up the maritime supply chain;

other shore-based means of transportation connect seaports with the hinterland, and maritime transit between important seaports (Nguyen et.al, 2022).

Accordingly, Southeast Asia was made up of 11 countries, which is typically separated into "island" and "mainland" zones and stretches from eastern India to China. Southeast Asia's island nations and maritime nations include Malaysia, Singapore, Indonesia, the Philippines, Brunei, and the newly independent East Timor (formerly part of Indonesia). Natural resources are abundant in Malaysia, including oil and gas, rubber, palm oil, and tin ore. The Straits of Malacca, which connect the Indian Ocean to the Pacific Ocean and the major Asian economies of India, China, Japan, South Korea, and ASEAN to the rest of the globe, rank among the most significant international waterways since the 7th century.

In addition, Malaysia's seven major seaports—five of which are primarily utilized for containers and two for oil and gas—make a significant contribution to the country's development and economic expansion. Malaysia has become a marine nation as a result of being surrounded by water and being strategically situated along the busiest shipping route in the world (Hanafiah et.al, 2017). According to Malaysia Transport Minister, the Malaysian maritime industry generates roughly 40% of the nation's Gross Domestic Product (Sekaran, 2022). The local economy in Malaysia is significantly boosted by the maritime sector. The oceans off the coast of Malaysia act as host shipping lanes, offering a platform for a prospective economic activities like travel, tourism, shipbuilding, ship maintenance, and port services (Menhat et.al, 2021).

Malaysia's maritime sector experienced a mixed development in 2022, with the shipping industry slowly steaming in rough waters, attempting to recover from the heavy blows of the COVID-19 epidemic, and rebuilding it under a lack of directional stability, although the ports have started to acquire speed (Sinar Daily, 2022). The long-lasting effects of COVID-19 have made shipping in Malaysia challenging. Because there have been so many lockdowns, the supply chain has been thrown off, which has made it harder to get products delivered on schedule and to find them. Because there aren't enough containers to meet demand, shipping costs have increased.

Moreover, due in part to the pandemic's gradual spread, Malaysia is currently recovering well from its consequences, with marine trade's contribution to GDP performing better than anticipated. The maritime sector is expanding slowly nonetheless, even though Malaysia's economy is expanding at various rates (Zaideen, 2023). Malaysia must therefore dramatically increase the efficiency, resiliency, and greenness of its port and shipping industry if it is to be completely equipped for the future. Technology developments, evolving trading patterns, environmental concerns, and regulatory changes have all contributed to the industry's substantial changes in recent years. The future of the sector and the parties engaged are profoundly impacted by these challenges.

Moreover, leading shipbuilders and operators aim to innovate by using state-of-the-art systems and technology that go beyond conventional designs to produce ships with cutting-edge remote control, communication, and networking capabilities. However, modern ships make great use of automation and IT systems, which gives hackers and other bad actors an additional opportunity to launch various cyberattacks that could result in catastrophic events and inflict significant safety losses (Akpan et al., 2022). Due to an increased reliance on technology and digital systems, the maritime industry in Malaysia, like in many other nations, confronts severe cybersecurity challenges. In terms of the busiest container ports worldwide, Port Klang and Port of Tanjung Pelepas were rated 12th and 18th, respectively, in 2019. (UNCTAD, 2020). Nonetheless, these ports' significance makes them potential targets of cyberattacks (Tan and Mohamad, 2021).

Furthermore, according to Sichun (2022), the most difficult and important problem that the maritime sector will face in the coming years is clearly maritime sustainability. Maritime used to take environmental sustainability for granted while neglecting the damage that the sector is doing to the environment. Furthermore, Yusof (2022) cited that in Malaysia, the maritime industry will have a difficult time reducing emissions because shipowners will continue to place a high priority on the need to preserve a low-cost transportation model. Consequently, Zaideen and Ramli (2022) mentioned that it is essential to raise awareness of the need for net-zero carbon emissions among the nautical community in Malaysia. This paper aims to identify the challenges of maritime industry in Malaysia.

## **2.0 LITERATURE REVIEW**

### **2.1 SUSTAINABILITY CHALLENGES**

Directly and indirectly, the International Maritime Organization (IMO) has significant influence over sustainability issues in the shipping, port, and maritime logistics sectors, as stated in the IMO Convention, which states that the organization's main goal is to conserve and use ocean resources in a "sustainable" manner (Lee et al., 2019). In the existing literature, three notable special issues have tried to deal with sustainability in maritime industry. However, in this study, environmental sustainability is a focus. One of the main forces behind the development of sustainable practices in organisations is environmental regulations and laws. Businesses make investments and work hard to fulfil basic sustainability standards but doing so may limit their capacity to apply creativity and innovation to sustainable business practises (Jović et.al, 2020).

Sustainability is the capacity to deliver services with negligible negative effects on the environment and natural resources (Wu et al., 2020). Concern has been expressed by the International Maritime Organization (IMO) regarding the protection of the world's waters from marine pollution. The unauthorized or unintentional release of solid trash is just one of many contaminations that have been identified as having a negative impact on ocean health (Mobilik and Hassan, 2016). Environmental sustainability must encourage environmental management efforts. In more detail, it encourages actions to lessen emissions, advance environmentally friendly technology and renewable energy sources, and maintain programmes aimed at attaining environmental sustainability (Argyriou et al., 2022).

### **2.2 CYBERSECURITY CHALLENGES**

Over the years, cyberattacks have been rapidly increasing. Due to this, businesses face big financial losses for them to recover. The losses also include collateral damage, such as reputation and trust. This is because the information and communication technology (ICT) sector has advanced significantly over the past 50 years and is now pervasive and deeply ingrained in our contemporary culture. The cost of cybersecurity risks is expected to reach US \$6 trillion annually by 2021, and since COVID-19, the number of attacks has multiplied five times (Williams et al., 2020). Due to that, a combination of technologies and procedures known as cybersecurity are used to safeguard computers, networks, programmes, and data from damage, theft, and illegal access (Sarker et al., 2020). The authors also mentioned that as a result, security policymakers have recently shown tremendous worry about safeguarding ICT systems and applications against cyberattacks.

Cybersecurity is currently a term used to describe the process of defending ICT systems from various cyberthreats or attacks. Consequently, a cyber-attack is characterized as a direct attack initiated from one or more computers against another computer, a group of computers, or the



networks involved (Neo, 2021). He also mentioned that as more operational technology (OT), such as cargo handling systems at ports and engine control systems on board ships, is connected to the internet, cyberattacks have an impact on the real world. Thus, there is a considerable increase in maritime cyber-security events as the threat is becoming more and more obvious. The primary goals of these attacks are to take remote control of ships and other vessels, to steal crucial information that can be used to launch additional attacks, or to interfere with ship operations by tampering with critical components and rendering automated systems inoperable (Farah et al., 2022).

### **3.0 METHODOLOGY**

This study has been done by reviewing two cases from journals to collect relevant information regarding the challenges of maritime industry in Malaysia. These two journals were used to identify two main challenges faced by Malaysia maritime industry.

“Factors Influencing Malaysian Maritime Industry in Remaining Sustainable in Global Trade” by Hanafiah et.al (2017) has been reviewed and the findings show there were three main issues in Malaysian maritime industry. In the literature, it was mentioned three issues related to sustainability which are operational, environmental and human resources issues.

Furthermore, another journal reviewed is written by Noor (2022) entitled “Addressing cyber security Vulnerabilities and Initiatives in Malaysia maritime industry”. The study provides a detailed discussion of the cybersecurity in maritime industry in Malaysia.

This qualitative case study is an approach to explore the challenges of maritime industry in Malaysia by using a variety of data sources. This method will ensure that the issue discussed in this research is explored through a variety of lenses rather than through one lens. This situation will lead to the multiple facets of the phenomenon being understood.

## **4.0 FINDINGS AND DISCUSSION**

### **4.1 SUSTAINABILITY CHALLENGE**

The world's total deadweight tonnage of container ships reflects the impact that the shipping industry has on global supply chain management. Yet, it is important to identify any potential influencing factors to make sure that Malaysia's maritime industry can sustain to participation in international trade. These factors include operational challenges, environmental issues, and issues related to human resources and the environment. However, this study focuses on environmental issues since ships are employed in the shipping sector to convey goods around the globe. A growing number of people are aware of the contribution that maritime transportation may make to global sustainability imperative. Many nations, including Malaysia, are dealing with environmental problems brought on by the expansion of maritime trade. According to Hanafiah et al., (2020), the primary problem brought on by maritime activities, such as oil spills from tankers and ballast water, which are known to pose risks to aquatic life, is marine pollution. Ritchie (2022) mentioned that Asia's rivers are the primary source of land-based plastic waste in the oceans. greater than 80% of it. However, large and intricate networks make maritime supply chains challenging to track in terms of environmental practises, changes in coastal hydrology, and greenhouse gas footprints (Fernando et al., 2019). Furthermore, the maritime industry's industrial structure is rapidly evolving. The environmental sustainability for this sector has become more difficult because of these changes.

Additionally, it results in an economic loss in terms of the overall amount of liabilities and compensation funds.

Hanafiah et. al (2020) also mentioned that with fossil fuels being its primary energy source, Malaysia is likewise affected by the global carbon dioxide (CO<sub>2</sub>) emission problem. A large increase in the release of hazardous gases into the atmosphere is a result of the high energy demand brought on by industrialization and rapid economic growth. This sector also contributes to pollution through its sulphur emissions. Uncontrolled emissions of these toxic gases may cause the greenhouse effect, which is bad for human health, the environment, and the next generation. As a result, this presents a challenge to developing Malaysia to reduce emissions while balancing them with the demands of economic development that depend on the use of these fuels.

## **4.2 CYBERSECURITY CHALLENGE**

Nowadays, most of the maritime sector is moving towards technologically advanced for improved ocean stewardship in order to take advantage of growth prospects. The sector is under constant pressure to satisfy the demands of the commercial marketplace and adhere to the International Maritime Organization's (IMO) carbon emission limits (Malaysian Investment Development Authority, 2021). Furthermore, one of the ways in integrating technology into the marine industry is by having automated ships. As a tool for increased efficiency and cost savings, automation is gaining popularity among shipowners (Berti, 2021). Moreover, maritime informatics' applied discourse has recently begun to focus on the role that digitization plays in marine logistics operations. Even though the maritime logistics business is made up of numerous actors, including shipping firms, rail operators, seaport and inland terminal operators, and freight forwarders, however, each element of maritime logistics needs to focus on its own digital transformation (Raza et al., 2023).

Cybersecurity dangers have therefore been increasing in the maritime industry. Becoming the target of cyberattacks on ships may seem strange. However, the growing usage of satellite communications and industrial control systems (ICS) has given hackers a new arena to play in (Tan and Mohamad, 2021). Furthermore, the literature also mentioned that while addressing cyberthreats, it's critical to keep in mind how unique maritime operational technology (OT) systems are because these components control the actual environment. A cyberattack aims to modify, remove, or steal data from a system as well as to disrupt, demolish, or control computer networks and systems. Maritime logistics could be negatively impacted by a very high risk of cyberattack (Noor, 2022). For instance, in May 2020, hackers gained access to the computers at the Iranian Shahid Rajaei Port, causing them to malfunction. As a result, the port's approach was severely congested on both land and waterways. To Israeli hackers, the cyberattack was attributed (Ismail and Main, 2021).

There are many challenges to consider, such as the fact that operational technology systems are responsible for real-time performance, incident response is time-critical to ensure the high reliability and availability of the systems, and access to OT systems should be strictly controlled without obstructing the necessary human-machine interaction. However, due to OT systems are designed to assist operational processes, they may not have the memory or processing power to handle the addition of security capabilities. The safety of the crew and the cargo on board, as well as the environment's health and the ship's ability to operate, may all be seriously compromised by OT system malfunctions (Arampatzis, 2020).

## 5.0 CONCLUSIONS

In contrast to the rising demand the sector saw during the pandemic, global shipping executives are struggling with declining exports, dropping freight rates, and growing anxiety about whether the industry is headed for a pricing war (Paris, 2023). The author also mentioned that early in the epidemic, there were lines of more than 100 ships off the coast of Southern California due to the surge in global demand for products. Since then, growing inflation has reduced demand for a variety of items as Americans have switched more of their expenditure to food, fuel, and services, leaving stores with an abundance of goods. In Malaysia, the shipping tonnage and number of shipping businesses are declining due to a lack of achievement due to the Covid-19 outbreak which made the maritime industry halted recently (Mohamed, 2022).

However, in this study there are two main challenges were highlighted regarding to maritime industry in Malaysia which are sustainability and cybersecurity issues. To address the sustainability challenge, regulations have been implemented, such as the Sulphur 2020 and GHG reduction targets of the International Maritime Organization (IMO). To lessen the industry's environmental impact, more innovation and funding must still be put into cutting-edge technologies. According to the chairman of the Malaysian Shipowners' Association (MASA), Mohamed Safwan Othman, adopting green shipping techniques is a key priority for maritime industry in order to solve environmental challenges (Bakar, 2022). However, lack of cost allocation is the key issue. To assist them in making the switch to environmentally friendly shipping, ship owners need financing. This is due to the high cost associated with high-tech green ships.

The port operations, ship navigation systems, and shore-based information technology systems of shipping businesses are the most frequently vulnerable areas in the maritime realm. Malaysia must therefore strengthen its maritime cybersecurity posture. Even in traditional industries, interest in digitization and corporate transformation utilizing technology has surged. However, malicious cyberattacks against ports across the world have been widely reported (Tan and Mohamad, 2021). According to Noor (2022), the maritime sector should develop a plan to lessen the effects of cyberattacks. Becoming cyber-resilient means doing this. Cybersecurity needs to be continually improved. The requirement is to comprehend, evaluate, and implement the essential safeguards. But there is no such thing as being too secure. An organization can still be attacked and compromised, regardless of how established or safe it is. As a result, a company can always respond to an attack and lessen its effects if they know what to do. Furthermore, the rising use of digital technologies has made modern, autonomous ships attractive targets for high-profile hacks. In order to strengthen resistance against threats to internal and foreign security, a variety of countermeasures and comprehensive defense plans should be implemented (Akpan et al., 2022).

Governments, port authorities, shipping firms, and labour unions all have a crucial role to play in determining the direction of the sector. It is crucial to strike a balance between the industry's obligation to safeguard the environment, guarantee safety and security, and advance social and economic development, and the need for innovation and growth. The findings of this study show there are two main challenges that are faced by the maritime industry. These findings are required to advance the maritime sector in Malaysia and can be used to direct future investigations into other regions and industries. A more in-depth study can be done in the future to further discuss this topic. A study can be done by doing interviews with maritime organizations. It also may include another element such as trends in maritime industry and comparison can be done with other Asia countries.

## REFERENCES

- Akpan, F., Bendiab, G., Shiaeles, S., Karamperidis, S., & Michaloliakos, M. (2022). Cybersecurity Challenges in the Maritime Sector. *Network*, 2(1), 123-138.
- Arampatzis, A. (2020, August 2). The Biggest Challenges and Best Practices to Mitigate Risks in Maritime Cybersecurity. *Timewire*. <https://www.tripwire.com/state-of-security/biggest-challenges-best-practices-mitigate-risks-maritime-cybersecurity>
- Argyriou, I., Daras, T., & Tsoutsos, T. (2022). Challenging a Sustainable Port: A Case Study of Souda Port, Chania, Crete. *Case Studies on Transport Policy*, 10(4), 2125-2137.
- Ben Farah, M. A., Ukwandu, E., Hindy, H., Brosset, D., Bures, M., Andonovic, I., & Bellekens, X. (2022). Cyber Security in the Maritime Industry: A Systematic Survey of Recent Advances and Future Trends. *Information*, 13(1), 22.
- Fernando, Y., Jasmi, M. F. A., & Shaharudin, M. S. (2019). Maritime Green Supply Chain Management: Its Light and Shadow on The Bottom-Line Dimensions of Sustainable Business Performance. *International Journal of Shipping and Transport Logistics*, 11(1), 60-93.
- Hanafiah, R. M., Mokhtar, K., Menhat, M., Zaideen, I. M. M., & Mohd, J. (2017). Factors Influencing Malaysian Maritime Industry in Remaining Sustainable in Global Trade. *International Journal of e-Navigation and Maritime Economy*, 14 (2020).
- Ismail, M. F., & Main, S. J. (2021). Malaysian Shipbuilding and Ship Repair: Contributing to the National Maritime Agenda. *Malaysia: A Maritime Nation*.
- Jović, M., Tijan, E., Žgaljić, D., & Aksentijević, S. (2020). Improving Maritime Transport Sustainability Using Blockchain-based Information Exchange. *Sustainability*, 12(21), 8866.
- Lee, P. T. W., Kwon, O. K., & Ruan, X. (2019). Sustainability Challenges in Maritime Transport and Logistics Industry and its Way Ahead. *Sustainability*, 11(5), 1331.
- Menhat, M., Zaideen, I. M. M., Yusuf, Y., Salleh, N. H. M., Zamri, M. A., & Jeevan, J. (2021). The impact of Covid-19 pandemic: A review on Maritime Sectors in Malaysia. *Ocean & Coastal Management*, 209, 105638.
- Mobilik, J. M. & Hassan, R. (2016). Pollution Threat from Shipping Activity Towards Ocean Sustainability. *Aquatic Science Colloquium 2016: Experiences Sharing in Aquatic Science*
- Mohamed, H. H. (2022, April 12). Malaysian Shipping Struggling to Catch up, While Ports 'anchors aweigh' from Troubled Waters. *BERNAMA*. Retrieved March 14, 2023, from <https://www.bernama.com/en/business/news.php?id=2144749>
- Neo, C. M. (2021). The Rising Threat of Maritime Cyber-attacks: Level of Maritime Cyber-security Preparedness along the Straits of Malacca and Singapore. *Royal Australian Navy Sea Power Soundings*
- Nguyen, T. T., My Tran, D. T., Duc, T. T. H., & Thai, V. V. (2022). Managing Disruptions in the Maritime Industry—a Systematic Literature Review. *Maritime Business Review*.
- Noor, M. M. (2022). Addressing Cyber Security Vulnerabilities and Initiatives in Malaysia Maritime Industry. *Journal of Maritime Research*, 19(3), 89-95.
- Paris, C. (2023, March 2). Idled Ships, Empty Containers. Ocean Shipping Faces its Biggest Slump in Years. *The Wall Street Journal*. Retrieved March 14, 2023, from

<https://www.wsj.com/articles/idled-ships-empty-containers-ocean-shipping-faces-its-biggest-slump-in-years-6f8dfcc4>

- Raza, Z., Woxenius, J., Vural, C. A., & Lind, M. (2023). Digital Transformation of Maritime Logistics: Exploring Trends in the Liner Shipping Segment. *Computers in Industry*, 145, 103811.
- Ritchie, H. (2022). Ocean plastics: How Much Do Rich Countries Contribute by Shipping Their Waste Overseas? *Our World in Data*. Retrieved March 13, 2023, from <https://ourworldindata.org/plastic-waste-trade>
- Sarker, I. H., Kayes, A. S. M., Badsha, S., Alqahtani, H., Watters, P., & Ng, A. (2020). Cybersecurity Data Science: An Overview from Machine Learning Perspective. *Journal of Big data*, 7, 1-29.
- Sekaran, R. (2022, March 1). Maritime Industry is the Backbone of the Malaysian Economy, Says Transport Minister. *The Star*. Retrieved March 14, 2023, from <https://www.thestar.com.my/news/nation/2022/03/01/maritime-industry-is-the-backbone-of-the-malaysian-economy-says-transport-minister>
- Sichun, S. Y. (2022, December 30). Sherneese Yong Sichun, GDPSCM. SIPMM Publications. Retrieved March 14, 2023, from <https://publication.sipmm.edu.sg/author/sysichun/>
- Sinar Daily. (2022, December 4). Malaysian Shipping Struggling to Catch up, While Ports 'Anchors Aweigh' From Troubled Waters. *Sinar Daily*. Retrieved March 14, 2023, from <https://www.sinardaily.my/article/185720/malaysia/national/malaysian-shipping-struggling-to-catch-up-while-ports-anchors-aweigh-from-troubled-waters>
- Tan, J., & Mohamad, M. Z. (2021). Improving The Maritime Cybersecurity in Malaysia. *MMA Bulletin* 2021.
- United Nations Conference on Trade and Development (UNCTAD). (2020). Review of Maritime Transport 2020. United Nations. [https://unctad.org/system/files/official-document/rmt2020\\_en.pdf](https://unctad.org/system/files/official-document/rmt2020_en.pdf)
- Williams, C. M., Chaturvedi, R., & Chakravarthy, K. (2020). Cybersecurity Risks in a Pandemic. *Journal of medical Internet research*, 22(9), e23692.
- Wu, X., Zhang, L., & Luo, M. (2020). Current Strategic Planning for Sustainability in International Shipping. *Environment. Development and Sustainability*, 22, 1729-1747.
- Yusof, A. (2022, February 5). Emissions Reduction Poses Greater Challenge for Shipowners. *New Straits Time*. Retrieved March 14, 2023, from <https://www.nst.com.my/business/2022/02/768829/emissions-reduction-poses-greater-challenge-shipowners>
- Zaideen, I. M. M., & Ramli, M. F. (2023). Malaysia's Maritime Sector Needs to be More Efficient, Resilient and Green. *Maritime Fairtrade*. Retrieved March 14, 2023, from <https://maritimefairtrade.org/malaysias-maritime-sector-needs-to-be-more-efficient-resilient-and-green/>
- Zaman, I., Pazouki, K., Norman, R., Younessi, S., & Coleman, S. (2017). Challenges and Opportunities of Big Data Analytics for Upcoming Regulations and Future Transformation of the Shipping Industry. *Procedia engineering*, 194, 537-544.

**ENGINE-ROOM SIMULATOR (ERS) AS ASSESSMENT TOOL IN HIGHER EDUCATION: CASE STUDY OF A MARITIME EDUCATION & TRAINING INSTITUTION IN MALAYSIA**

Zaful Rullah Hakiem Bin Zaini  
zaful.rullah@alam.edu.my

*Centre for Professional Training (Simulator), Akademi Laut Malaysia, BT 30 Kg Tg Dahan, 78200 Kuala Sungai Baru Melaka, Malaysia*

**ABSTRACT**

This research investigates the underutilisation of Engine-Room Simulator (ERS) as an assessment tool for marine engineers in Malaysia. The study focuses on a Malaysian Maritime Education and Training Institute (METI) offering a Diploma in Marine Engineering and aims to explore educators' perspectives on the usage of ERS, how ERS is incorporated into METI programmes, challenges to its implementation, and sustainability plans. The research methodology involves semi-structured interviews with relevant key persons from a METI. The study intends to offer more insights into ERS implementation's current practices and sustainability plans in METIs, benefiting maritime educators and increasing seafarers' proficiency and competency.

**ARTICLE INFO**

*Keywords:*  
*Engine room simulator, ERS' Maritime education and training, Maritime simulator, Marine engineer*

**1.0 INTRODUCTION**

Incorporating simulators into the curriculums of Maritime Education and Training (MET) institutions has been standard practice for the past few decades. Initially, simulator-based training was implemented to develop navigational skills such as passage planning and coordination between the master and harbour pilot. This was the original goal of the programme. Today, simulators may be used in various applications within the maritime industry. These applications include training for transferring operations, navigation operations, cargo handling, engine control, and anchor handling (Hanzu-Pazara et al., 2008). The term "simulator" is a depiction of a real scenario generated by the by-products of mechanical, electromechanical, or computer systems is what is meant by the term "simulator." The expensive cost of the original equipment and the difficulties in gaining access to the actual piece of machinery to carry out the necessary training or research in a secure environment are the primary factors that contribute to the utilisation of the Engine-Room Simulator (ERS) in MET (Stetsenko & Stetsenko, 2019). Several types of training cannot be repeated in the real

world for reasons relating to safety. The usage of marine simulators as training and examination instruments are mandated by the international convention of Standard of Training, Watchkeeping, and Certification (STCW) (Fisher & Muirhead, 2019).

Despite the numerous advantages of using ERS as an assessment tool for marine engineers, Malaysia still has not fully utilised this technology. Although ERS can provide a realistic and cost-effective method for assessing the abilities and knowledge of marine engineers in a secure environment, Malaysia Marine Department (MARDEP) still obligate the primitive approaches, namely, written tests and oral examination, as tools for evaluating the competency of marine engineers (Malaysia Marine Department, 2021), prior issuing the Certificate of Competency (COC) as a marine engineer. This underutilisation of ERS in Malaysia may have resulted in lost chances to enhance digital skills and improve the competency and proficiency of marine engineers.

## **2.0 LITERATURE REVIEW**

Marine engineers are highly qualified experts who play a crucial role in the maritime industry. They serve as watchkeepers who maintain the engines, boilers, and other technical systems aboard ships and other marine vessels (Laskowski et al., 2015a). Marine engineers are essential to ships' safe and effective functioning, and they play a crucial role in assuring the safety of passengers, crew, and cargo. Marine engineers are vital to the worldwide shipping sector due to their technical expertise and knowledge of safe maritime operations, including environmental protection from ship pollution (Laskowski et al., 2015a).

The International Maritime Organization (IMO) is a United Nations specialised body regulating maritime affairs and promoting maritime safety and environmental preservation. The IMO has defined requirements and standards for the education, certification, and evaluation of marine engineers (International Maritime Organization, n.d.). These criteria are outlined in the International Convention on Standards of Training, Certification, and Watchkeeping for Seafarers (STCW) and its corresponding rules and guidelines.

To become a globally certified marine engineer, a person must satisfy the STCW's education, training, and examination criteria. Typically, this entails completing a recognised marine engineering degree, earning seagoing experience on a ship, and passing academic and practical exams (International Maritime Organization, 2017b).

The IMO also establishes minimum medical requirements for seafarers, including marine engineers. These requirements are intended to guarantee that marine engineers are physically and psychologically fit to perform their tasks safely and efficiently (Jensen et al., 2022).

The IMO collaborates closely with maritime organisations, governments, and industry partners to ensure that the standards for marine engineers are properly implemented and that seafarers obtain the training and certification necessary to operate in a safe and efficient manner.

By creating and enforcing international standards for marine engineers, the IMO plays a crucial role in safeguarding the environment and ensuring the safety and efficiency of global maritime operations (Mukherjee & Brownrigg, 2013).

Maritime Education and Training Institutions (METIs) are crucial in educating students about careers in the marine industry. They provide various programmes and courses to equip students with the information and skills required to work aboard ships, in ports, and other maritime-related industries (Milić-Beran et al., 2021). METIs give students the opportunities necessary to pursue successful careers in the marine industry, from basic safety training to advanced technical studies.

Malaysia Marine Department (MARDEP) acts as a maritime administrator under the umbrella of the Ministry of Transportation (MOT), in charge of monitoring seafarer certification and training, which includes ensuring that METIs meet accreditation criteria and that their training programmes are effective and comprehensive. This could include inspecting and auditing METIs, examining curricula and training materials, and monitoring the performance of their instructors and students.

MARDEP is also involved in the development and implementation of policies and regulations pertaining to seafarer training and certification, which may include establishing standards for the knowledge, skills, and competencies that seafarers must possess to work on board ships. MARDEP may also work with other maritime administrations and industry stakeholders to exchange best practices and improve the overall quality of seafarer training and certification programmes around the world.

Overall, the MARDEP's role in ensuring seafarers' competency through METIs is to ensure that seafarers are properly trained and certified to perform their duties safely and effectively and encourage seafarers' ongoing professional development throughout their careers.

Evaluating marine engineers' knowledge and abilities is crucially dependent on assessment. It helps to determine the level of competence and professionalism of maritime industry employees. Written examinations, practical assessments, and on-the-job assessments are among the ways to evaluate marine engineers' skills (Zincir et al., 2017). These assessments play a vital role in ensuring that marine engineers can perform their jobs safely and effectively and possess the knowledge and skills required to meet the demands of their profession.

The Engine-Room Simulator (ERS) is a highly advanced assessment instrument that plays a growing role in assessing marine engineers. The ERS provides a realistic, simulated environment where marine engineers can demonstrate their knowledge, skills, and talents in a safe and controlled setting (Zaini, 2020).

ERS is designed to simulate the conditions and systems in a ship's engine room, including the main engines, boilers, pumps, and other vital systems. It allows maritime engineers to practise and demonstrate their skills in various conditions, ranging from everyday operations to emergencies (International Maritime Organization, 2017a)

ERS offers various advantages over traditional assessment methods and provides a secure and controlled environment for testing. ERS can provide instant feedback on the work of maritime engineers, enabling them to discover areas for development and get specialised training. ERS also provides a consistent and standardised evaluation tool, which ensures that marine engineers obtain objective and fair evaluations of their talents (Cicek, 2017)

### **3.0 METHODOLOGY**

The data gathering was carried out using a qualitative method. Since this study aims to investigate the current status of METI concerning using ERS as an assessment tool, the qualitative method is the most efficient approach to accomplish the goal.

#### **3.1 Interview method**

Because the interview provides clarity and enables respondents to respond to open-ended questions in greater depth, it was selected as the data collection method because of its versatility (Brace, 2013). This resulted from the respondents' considerable involvement in the marine business and their comprehensive understanding of the industry. Interviews are the method of choice when answering the questions posed in the research. However, a substantial amount of reliance is placed on the information provided by the respondents (Ghauri & Grønhaug, 2005). This is true regardless of whether or not the respondents are biased. Semi-structured interviews



were favoured over other types because they enabled information to be compared among respondents and provided greater flexibility. This made it possible to obtain more useful information (Dawson, 2006).

### 3.2 Interview Protocol

**Introduction:** The researcher took a moment to introduce himself and his theory before the interview got underway. The researcher gave the participants an explanation of why their participation was necessary for the researcher to gather the required information, what would happen with the information obtained, and how the community would benefit from the knowledge.

**Key questions:** The data-gathering process was carried out through a method known as semi-structured interviews. The following are some general rules for interview questions, followed by more in-depth questions that probe further.

1. What is your perspective on using ERS as an assessment tool for METI?
2. How is ERS incorporated into your training programmes?
3. What are the challenges to implementing the usage of ERS as an assessment tool in METI?
4. How do we sustain the implementation of ERS as an assessment tool for METI?

**Probing questions:** By asking participants more in-depth questions regarding the significance of their comments, researchers persuaded participants to think more carefully about the significance of their comments. These questions were beneficial because they encouraged participants to contemplate the root or foundation of the problem the researcher was looking into.

**Closing questions:** Before the final questions were asked, the key informants were given the opportunity to make any final comments or provide any further information. During the closure, it was also requested of the key informants whether they had any ideas or solutions to offer concerning the issue.

**Summary:** The researcher gave a concise explanation of the primary topics addressed during the interview and checked with the subjects to ensure he had covered all pertinent information. The final inquiry that the researcher posed to the participants was whether there was anything else they would like to discuss with the researcher. In closing, the researcher conveyed their appreciation for their participation and time.

Every single one of the interviews was captured on an audio recorder. Due to the limited time available during the interview sessions, the researcher was required to follow up on a few topics via email and the Whatsapp mobile app. The transcriptions were independently checked with each participant to ensure the data's accuracy.

#### 3.2.1 Ethical consideration

This qualitative study aims to conduct in-depth and adaptable research on a topic. This method was employed to gain a deeper understanding of METI's educators' viewpoints and METI on the utilisation of ERS as an assessment tool. Due to ethical considerations, the HEI's upper management has authorised permission to use data and research samples under the following conditions: if part or all of the study findings are to be published, the final copy of the research report must be presented to management, and prior approval must be obtained. After obtaining ethical approval for the study from the institution and higher authorities, educators in the METI were chosen on purpose to participate in this research. Participants signed a permission form

and were advised that they might withdraw at any time. Only data from participants who consented to participate were included.

### 3.2.2 Profile of the key informants

Data were gathered using specially constructed study interviews based on the predetermined research topics. For this experiment, individuals were chosen using a carefully chosen sample strategy. The participants were selected from various positions and duties at METI in Malaysia. Participation was entirely voluntary, and there was no inducement offered. The information was taken between February 13 and February 20, 2023. Before the interviews, each participant signed a consent form.

<b>Criteria</b>	<b>P1</b>	<b>P2</b>	<b>P3</b>	<b>P4</b>
<b>Gender</b>	Male	Male	Male	Male
<b>Age</b>	41	36	41	50
<b>Shipboard experience</b>	5 years	12 years	5 years	9 years
<b>Educations</b>	Master in Mechanical Engineering, Degree in Electrical Engineering	Master in Mechanical Engineering (ongoing), Diploma in Marine Engineering	Master in Mechanical Engineering (ongoing), Degree in Electrical Engineering	Diploma in Marine Engineering
<b>*COC type</b>	Electrotechnical Officer	Second Engineer Officer	Electrotechnical Officer	Chief Engineer Officer
<b>Position</b>	Senior lecturer	Lecturer	Lecturer	Senior lecturer
<b>Teaching experience</b>	13 years	4 years	5 years	19 years
<b>**SME</b>	Marine electrical engineering	Marine engineering	Marine electrical engineering	Marine engineering
<b>ERS involvement</b>	Electrical related courses/training	Nil	Electrical-related courses/training	Nil
<b>Interview duration</b>	44 minutes	25 minutes	35 minutes	30 minutes

**\*COC: Certificate of Competency**

**\*\*SME: Subject Matter Expert**

Table 1: Profile of the key informants

Two senior lecturers with more than ten (10) years of teaching experience and two junior lecturers with lesser teaching experience were selected as participants. All of them are former

seafarers and involve in teaching for the COC program. Under the faculty of marine engineering (FAME), two fields were involved in the interviews: marine mechanical engineering and electrotechnical engineering.

The goal of interviewing people from varied backgrounds is to obtain thoughts and viewpoints from a wide range of people to generate a more thorough and nuanced understanding of the topic under research. By interviewing people from various backgrounds, the researcher may learn about how different people or groups experience or perceive a similar issue and how this varies across cultural, social, and demographic lines.

This method is beneficial when investigating complex or controversial topics since it allows us to gain a more nuanced knowledge of the various viewpoints and experiences within a specific group or community. It can also help to guarantee that our research includes a diverse variety of voices and that our findings apply to a diverse range of stakeholders.

Generally, the goal of interviewing people from varied backgrounds is to get a more comprehensive and inclusive understanding of the topic under research and to create insights and suggestions relevant and applicable to a wide range of people and organisations.

### **3.3 Secondary data**

During this research, the researcher additionally employed secondary data from the respective METI concerning the courses that use ERS as a learning and assessment tool to compare and analyse with all other data, such as;

1. Course specifications.
2. Evaluations forms.
3. Trainer's log.
4. Assessment reports

### **3.4 Data Analysis and Presentation**

All interview-related material, including video recordings, emails, and WhatsApp mobile app text messages, were professionally organised into files and folders. The subsequent phase includes numerous reading and listening sessions with simultaneous note-taking. Combining multiple codes is allowed for the selection of the most relevant ones and the creation of categories. The codes were categorised, and their connections were examined. Subsequently, the results were presented in a narrative format. Both deductive and inductive coding techniques were utilised in this method. However, because the researcher conducted an exploratory study and had to collect data from scratch, the inductive method was given greater weight (Christians & Carey, 1989).

In social science research, triangulation, a strategy that employs many case studies, is widely applied. This method is recommended since it enhances validity (Campbell & Fiske, 1959), makes sense of the data, and classifies it into the appropriate categories (Creswell, 2013). All primary and secondary data are compared for triangulation

## **4.0 FINDINGS**

This chapter is organised to provide a comprehensive summary of the research findings. It begins with a summary of the collected data. The principal findings are then presented as

themes, patterns, and insights derived from the data. Each theme is examined in depth, with supporting evidence to illustrate the findings.

#### 4.1 Educator perspectives

Key question	Answers from participants
<p>What are educators' perspectives on using ERS as an assessment tool for METI?</p>	<p><b>Advantages of using ERS</b></p> <ul style="list-style-type: none"> <li>• ERS gives the reflection of reality onboard the ship. (P2, P4)</li> <li>• The automated assessment produces marks faster (P2)</li> <li>• Ease the workload of the assessors. (P1, P3, P4)</li> <li>• The approach is in-line with IR4.0. (P4)</li> <li>• Benchmarking the aviation industry (P4)</li> <li>• The trainers can learn from ERS. (P1)</li> <li>• To meet industrial demand. (P4)</li> </ul> <p><b>Complement vs replacement</b></p> <ul style="list-style-type: none"> <li>• To complement the existing assessments. (P1, P2, P3)</li> <li>• ERS assessment helps to bridge the gap of the current assessment approach. (P1, P3)</li> <li>• Possible to be a total replacement of the existing assessment. (P4)</li> </ul> <p><b>Focus areas to be assessed</b></p> <ul style="list-style-type: none"> <li>• Suitable for evaluating critical and analytical thinking. (P1, P4)</li> <li>• Suitable for evaluating technical skills and procedural knowledge. (P1, P3)</li> <li>• Variety applications at all levels. (P1)</li> <li>• Fair assessment tool for know-how candidates but also poor communicators (P1, P3)</li> </ul>

**Table 2:** Summary of information related to the RQ1

From the interviews, all the participants gave positive perspectives concerning using ERS as an assessment tool. P4 highlighted that the aviation industry has been using this approach since before, and the method is proven effective. ERS-based assessment is also perceived as in line with the education of IR 4.0, which aims to produce a generation with excellent critical and analytical thinking skills. As a result, the future generation may have the skills that are highly demanded in the modern workforce, which will be highly automated.

Even though P2 and P4 have never used them as teaching or assessment tools, both of them have experienced attending several ERS-based training. The majority of participants agreed that ERS-based assessment is to complement the flaws in the existing assessment approaches. However, P4 believes that ERS can replace the existing assessment methods with the correct approach.

P3 believes only certain aspects can be assessed in the ERS, such as technical skills, procedural knowledge and troubleshooting. It helps poor communicator candidates who understand and know how to perform tasks but have limitations in explaining things through writing or oral conversation. P1 and P3 agreed that candidates with good language ability could perform better in written and oral assessments.

According to P3, the workload of the assessor can be reduced as automated assessment from ERS can generate immediate results with reports. The assessment will become more objective, and this method can assess specific knowledge.

Although the study focuses on the COC programme of undergraduates, P1 explained that ERS-based assessment could be further expanded to the postgraduate level, which involves more managerial skills rather than technical skills.

#### 4.2 Incorporation of ERS

Key question	Answers from participants
How is ERS incorporated into METI programmes?	<p><b>Positive</b></p> <ul style="list-style-type: none"> <li>• ERS is used as an assessment tool in the High-Voltage course. (P1, P2)</li> <li>• ERS is occasionally utilised as a learning tool (P1, P3)</li> <li>• ERS is utilised for short courses, which are handled by another department. (P2)</li> </ul> <p><b>Negative</b></p> <ul style="list-style-type: none"> <li>• It's not part of the training or assessment tool for the COC programme (P1, P2, P3, P4)</li> <li>• MARDEP doesn't obligate the usage of ERS for the COC programme (P1, P2 &amp; P4)</li> <li>• The number of ERS workstations is limited. (P1)</li> <li>• Less initiative from other lecturers. (P1)</li> <li>• ERS does not apply to all engineering topics. (P2, P4)</li> </ul>

Table 3: Summary of information related to the RQ2

From the data collection, only P1 and P3 use ERS as teaching and assessment tool. Both of them incorporate ERS in a short course of marine electrical High-Voltage. In this short course, the hybrid ERS is used, which consists of a combination of a simulator and a physical Vacuum Circuit Breaker (VCB) real equipment. However, the training is not specifically for the COC program but for active seafarers who intend to sail onboard high-voltage vessels. MARDEP strictly regulates this high-voltage course.

However, P1 also takes the initiative to incorporate the ERS in his COC program. According to P1, he only brings the undergrad students, also known as cadets, if the ERS is available. The ERS is managed by another department which specialises in short courses.

All participants agreed that no requirement by the authority body causes very low utilisation of the ERS in the COC programme. P2 and P4 also mentioned that ERS is more on application than engineering fundamentals. Therefore, ERS is perceived as not relevant to all engineering

topics. P1 also emphasised that multiple factors, such as the high workload of the lecturers, may cause low utilisation. The lecturers must be well-trained and spend hours to be familiarised with the ERS system. A limited number of ERS is another factor, as it requires good planning and management to enable all students to have the opportunity to use them.

From other secondary data, the researcher found that ERS is mainly utilised for short courses, which are mostly non-obligatory for the COC programme. Some shipping companies require an ERS-based assessment to promote marine engineers in the industry. The ERS is also used as a platform to assess the non-technical skills in resource management courses, and the training is regulated by MARDEP. The average rating for the course evaluation is 4.8 out of 5.0.

### 4.3 Challenges of Implementation

According to P4, the simulator manufacturer only provides the training package if the METI purchases the equipment, and further training will require additional costs. Therefore, the practice in the METI is only one-time training; the rest will be self-learning by the respective trainers. The ERS in the institution was installed in 2006. It means whoever joins the METI after that has missed the opportunity to attend the formal training. Even the current person in charge of the ERS has never received formal training, only learning from the previous senior lecturer how to operate the ERS as a learning and assessment tool.

P1 mentioned that in 2017, the METI purchased a High-Voltage Simulator, a small portion of ERS. Some of the current trainers in the METI have received formal training after the simulator installation by the maker. Nevertheless, this small simulator uses a different system and platform than the old ERS they already have. The ERS system is more complex compared to the High-Voltage simulator.

Key question	Answers from participants
<p>What are the challenges to implementing the usage of ERS as an assessment tool in METI, and how educators overcome them?</p>	<p><b>Challenges</b></p> <ul style="list-style-type: none"> <li>• The trainers need to be well-trained to operate the ERS (P1, P3, P4)</li> <li>• Inadequate resources such as simulator experts, time and the number of simulator workstations. (P1, P4)</li> <li>• Trainers need to spend long hours operating ERS to become experts. (P1, P4)</li> <li>• Familiarity of the students and trainers with the complex system of ERS. (P1)</li> <li>• Resistance by various parties due to increment of the cost. (P2, P4)</li> <li>• Sceptical towards changes. (P2)</li> <li>• Poor digital literacy, especially by the older generation. (P2, P4)</li> <li>• Equipment failure while handling the ERS. (P1)</li> </ul>

Table 4: Summary of information related to the RQ3

The trainers from FAME faced many challenges that caused low utilisation of ERS. As the ERS is managed by another department and solely used to generate revenue for the institution, other lecturers find it difficult to coordinate its usage. To become experts, the trainers must spend long hours operating the ERS. As an older generation previously dominated the METI with a lack of digital literacy, the learning process of handling the ERS was even more difficult.

As a result, the lecturer from FAME often asks for help from the simulator department to do the training on their behalf. Due to a lack of resources such as simulator experts, time and also the simulator workstation, the ERS sessions are not properly structured. The students may only utilise them whenever the dedicated ERS trainer is available.

#### 4.4 Sustainability of ERS

Due to METI being a private institution, the issue of cost was highlighted by most participants. Currently, ERS is categorised as a high-end teaching tool, which incurs a high price to the end users.

Many agreed that the restriction is due to the non-obligatory rule set by MARDEP on using the simulator in the COC programme. It effectively causes low demand by the end users. P4 highlighted that MARDEP must set the direction to make it compulsory for all METIs, including the sponsors. However, P1 disagrees with obligating the usage of ERS, as this will increase the financial burden for other METIs, especially those that operate at a lower budget. P1 and P2 believed that METI should be able to convince the stakeholders concerning the effectiveness of ERS so that it will be utilised even though there is no obligation and it is pricey.

Key question	Answers from participants
How do we sustain the implementation of ERS as an assessment tool for METI?	<ul style="list-style-type: none"> <li>• Diversify the sources of income using ERS to generate revenue. (P3)</li> <li>• METIs to convince various parties concerning the effectiveness of ERS. (P2)</li> <li>• The direction by MARDEP becomes a commitment by all parties. (P4)</li> <li>• ERS utilisation to be put as KPI criteria. (P4)</li> <li>• Internal sharing sessions by ERS experts to train other educators in ERS usage. (P4)</li> <li>• The usage of cloud simulation to increase the contact hours of ERS (train anywhere and anytime). (P1, P2)</li> <li>• METIs to convince various parties concerning the effectiveness of ERS. (P2)</li> </ul>

Table 5: Summary of information related to the RQ4

P4 also suggested that using ERS should become part of the key performance index (KPI) to encourage all trainers to use it. Once it is practised by all trainers, ERS could easily become the preferred assessment tool. A sharing or ‘echo’ training session on using ERS could be done among trainers to increase awareness and encourage use. This may speed up the learning process of other trainers at a minimum cost. P1 and P2 mentioned the usage of cloud simulation may help in the self-learning process for both trainers and students, as the concept is to learn ‘anywhere at any time’.

As ERS is going to increase the cost, P3 suggested that all parties should optimise the usage of ERS and diversify the source of income using ERS to generate more revenue which subsequently will prolong the sustainability of ERS.

## **5.0 DISCUSSION**

In this chapter, the researcher analyses, compares, and contrasts the results of this study with those of prior ones and discusses their implications, limitations, and contributions. It is the portion in which the researcher critically evaluates their study, identifying its merits and faults and recommending options for further research.

### **5.1 Planning and implementation of the change initiative**

#### **5.1.1 Planning**

ERS, as an assessment tool, has grown immensely in popularity in maritime education and training, as they provide a safe and regulated environment for students to enhance their skills and knowledge (Cicek, 2017). This discussion will examine the process of creating and implementing an ERS as an assessment tool in a maritime school.

Preferably, incorporating ERS as a learning and assessment tool should be considered throughout the curriculum design and development (CDD) phase. According to the participants, the primary obstacles to administering ERS training are financial, personnel, and facility-related. Hence, planning is essential to guarantee that the resources are well utilised to prevent waste.

The course developer must comprehend the comprehensive CDD process, especially when considering the ERS as a learning tool. The definition of CDD is as follows:

- Curriculum design: defining the curriculum's fundamental components and their interrelationships.
- Curriculum development entails the methodical and well-organised preparation of what must be taught and learnt to build a complete curriculum plan (Yoga, 2018).

The ADDIE model originated in the United States of America and is among the most extensive yet basic models or frameworks in the CDD process (USA). ADDIE is an acronym for analysis, design, development, and implementation. This paradigm is frequently utilised by training and education developers such as the Open University of the United Kingdom (UK) (Bates, 2015). Figure 1 is a concept map showing an overview of the CDD process using the ADDIE paradigm. As shown in the figure, the usage of ERS in the TLA is influenced by a variety of factors, including:

- the learning objectives
- the target audience
- the available time
- the costs
- the workforce
- and the learning aids.

As all participants agreed that ERS only applies to certain areas, the initial stage is to determine the simulation's goals, which may range from basic familiarisation to advanced problem-solving and decision-making skills. Also, the METI must define the sorts of vessels and



propulsion systems they seek to emulate and the level of realism necessary to obtain the desired results (Zaini, 2020).

After establishing the objectives, the METI must examine the space and equipment required to host the ERS. The ERS must imitate the layout and systems of the vessels in the METI's curriculum and be equipped with realistic controls, instruments, and displays (Laskowski et al., 2015b). In addition to real events and malfunctions, the ERS should give learners a realistic and ergonomic learning environment.

### **5.1.2 Implementation**

The implementation of an ERS includes the installation and testing of the simulator, the formulation of training programmes, and the evaluation of the performance of the learners (DNV-GL, 2020). During the installation and testing phase, the institution must confirm that the ERS is correctly installed and that all systems and controls are calibrated and operational.

The next stage is to run training programmes that utilise the ERS as planned in the CDD phase in the previous subchapter. The training programmes should be aligned with the ERS's objectives and developed to address the needs of learners with varying degrees of experience. Learners should be able to practise their abilities and receive feedback on their performance, and programmes should incorporate theoretical and practical components. METI should establish an effective ERS learning process before it can be used as a formal assessment tool. For a start, the METI may use the ERS as the formative assessment tool, either the assessment of learning (AOL) or the assessment for learning (AFL), as a carry mark for the final grades. Once the METI is comfortable with the system and various parties are convinced of its effectiveness, this ERS may be used for summative assessments.

## **5.2 The effectiveness of the change initiative**

Using ERS as a maritime education and training assessment tool has recently acquired substantial traction. Without the hazards and costs of running actual training ships, ERS provides trainees a safe and controlled environment to practise and enhance their skills and knowledge (Sellberg & Viktorelius, 2020).

As ERS is designed to simulate the real-world atmosphere of a ship's engine room, it also provides learners with a realistic and difficult educational experience. The simulators can be programmed to represent many types of ships and propulsion systems, and they can include

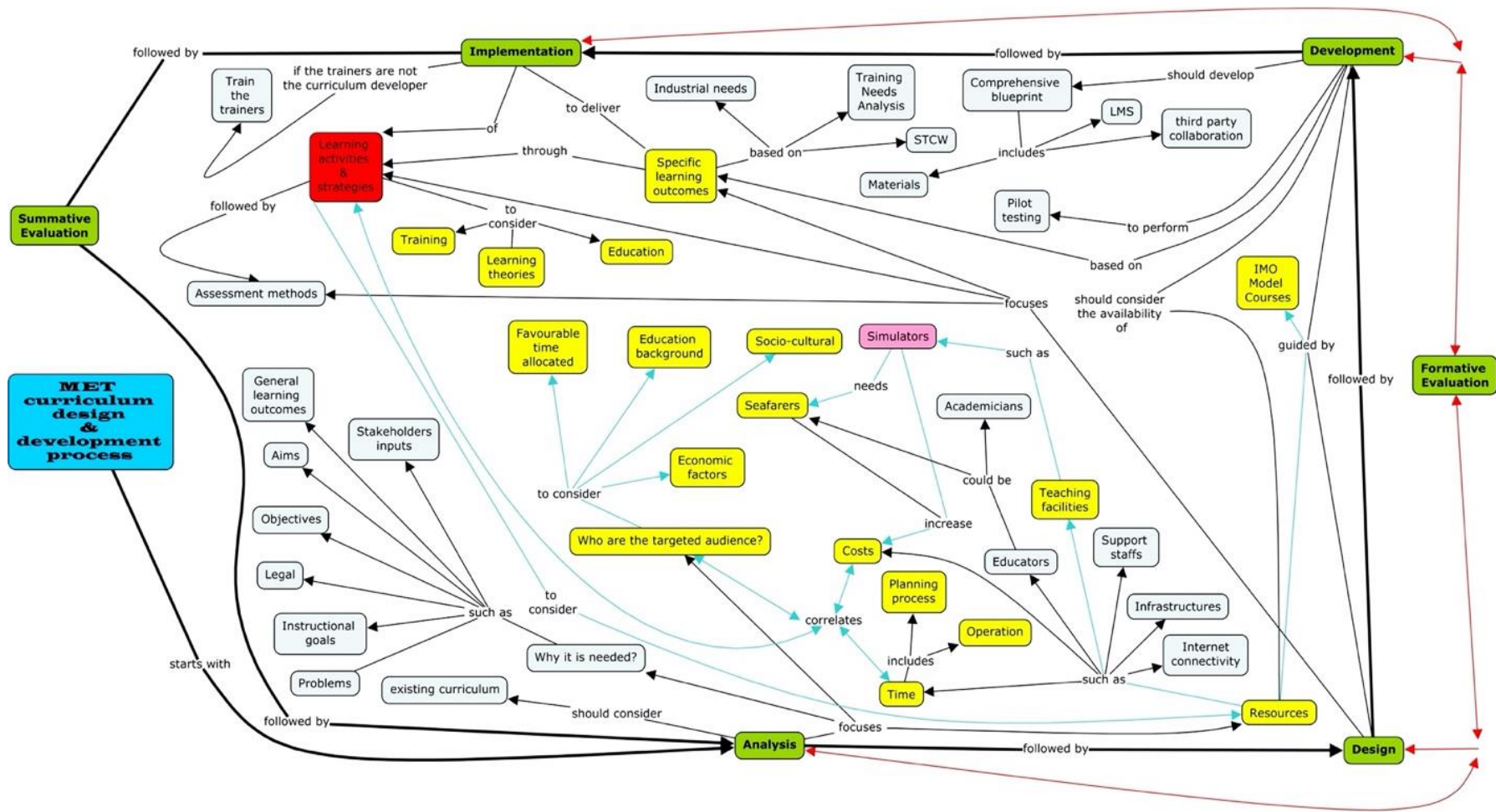

Figure 1: Concept map for METI curriculum design and development

Note. The figure illustrates the ADDIE approach to curriculum design and development. The key components of the ADDIE methodology are labelled in green. The yellow boxes represent the main factors determining ERS selection as a learning aid during the red-labelled procedure. Reproduced from *The Effectiveness of Engine Room Simulator (ERS) as a learning tool in maritime education and training* by Z. Zaini ([https://commons.wmu.se/cgi/viewcontent.cgi?article=2390&context=all\\_dissertations](https://commons.wmu.se/cgi/viewcontent.cgi?article=2390&context=all_dissertations)). Copyright 2020 by World Maritime University

realistic scenarios and faults to evaluate students' ability to troubleshoot and make judgements under duress. By giving learners hands-on experience in a realistic setting, ERS can improve their learning outcomes and prepare them for real-world scenarios (Stetsenko & Stetsenko, 2019).

Safety is one of the major benefits of utilising ERS as an assessment tool (Kluj, 2012). The ERS provides a controlled and risk-free environment for students to practise their skills and knowledge without endangering themselves, the vessel, or the environment. Learners can practise dealing with various scenarios and malfunctions without the inherent dangers of running actual ships, hence lowering the likelihood of accidents and casualties.

Traditional assessment techniques, such as aboard or shore-based training, are far less efficient than ERS (Bakalov, 2019). As learners can practise and develop their abilities in a simulated environment, using ERS decreases the time and cost associated with onboard training. In addition, ERS can be used to assess learners' abilities and knowledge quickly and accurately, enabling instructors to discover areas for development and modify training programmes.

ERS allows an objective evaluation of the abilities and knowledge of students, avoiding the possibility of subjective evaluations. ERS can monitor and record students' performance, producing data that may be used to assess the efficacy of training programmes and the ERS as an assessment tool (Cicek, 2017). By offering objective evaluations, ERS can improve the precision and dependability of the assessment process.

### **5.3 Critical factors for the sustainability**

Several essential elements determine the viability of an ERS as an assessment tool in a METI. These elements must be considered to guarantee that the ERS continues to suit the demands of students and instructors and stays an effective and valuable tool over time.

Most participants highlighted that the available resources are the most important critical factor for sustainability. Cost-effectiveness is a crucial aspect of its long-term viability. The ERS must be constructed to maximise cost-effectiveness, balancing purchase and maintenance expenses with its benefits. Besides, ERS is a complicated system requiring routine maintenance and support to ensure its functioning and reliability (Mallam et al., 2019). A maintenance and support plan that includes routine inspections, updates, and repairs is vital. This maintains the ERS's continued functionality and dependability over time, decreasing the risk of downtime and lost training opportunities. In addition, the ERS must be utilised efficiently to minimise downtime and maximise the number of students who can use it. The METI should be creative to secure funding or generate revenue for the sustainability of the ERS.

For the ERS curriculum to remain successful and relevant, it must be continuously examined and updated to match the demands of learners and the changing industry standards (Lovren & Popović, 2018). The curriculum must be adaptable to industry changes and incorporate the most recent trends and technologies. This guarantees that students have the skills and knowledge required for success in the real world. Using up-to-date technology is one of the most important criteria for the long-term viability of an ERS. The ERS must be developed to imitate the most up-to-date vessel and propulsion systems, using the most up-to-date technologies and features. This guarantees that students are trained on the latest equipment and equipped for real-world scenarios. The latest technology may also influence other stakeholders concerning the benefits and necessity of using ERS as an assessment tool. Perhaps, there will be less resistance by the clients and even invite more parties to give funding to sustain the usage of ERS.

The ERS must be fully utilised by integrating it with the learning environment. To give a holistic learning experience, the ERS should be utilised in conjunction with other teaching methods and materials, such as classroom lectures and hands-on training. Also, the ERS should be accessible and simple to operate, guaranteeing that students can utilise it without extensive training or assistance.

Although under international regulation through the STCW convention, simulator assessment is not mandatory (International Maritime Organization, 2017b), it doesn't mean Malaysia, as a developing country, cannot surpass the minimum requirements. Perhaps, it will be more helpful if the MARDEP itself sets stringent enforcement to obligate the usage of this instrument in both training and assessment.

## **6.0 CONCLUSIONS**

Planning and deploying an ERS assessment tool in a METI must consider the institution's demands, resources, and objectives. The successful execution of the simulator is contingent on the planning quality, the selection of suitable hardware and software, and the creation of efficient training and assessment programmes. Employing an ERS as an assessment tool can improve the quality of maritime education and training and the skills and knowledge of students.

ERS are an effective evaluation tool for marine training and education. The ERS provides a secure and controlled environment for students to practise and improve their skills and knowledge, improve learning outcomes, promote safety and efficiency, and provide objective assessments. As a result, ERS has become an integral part of METI, providing students with a practical and realistic learning environment that prepares them for real-world scenarios. It also helps to enhance the digital literacy of the students, which prepares them to adapt better to the rapid-evolving technologies.

The sustainability of an ERS as an assessment tool is contingent on several essential factors. These characteristics include cost-effectiveness, up-to-date technology, maintenance and support, relevant and flexible content and integration with the learning environment. By addressing these aspects, educators can guarantee that the simulator remains an effective and important maritime education and training tool. The approach should be holistic as all parties, such as maritime administration (MARDEP), shipping companies and METIs, should work together to ensure sustainability.

The results do not reflect the global use of ERS as an assessment tool due to the limited sampling region, a small number of participants, and time constraints.

In light of the findings, several suggestions for future research are given, including the following:

- Pedagogy of ERS assessment.
- Variety of assessment approaches using ERS.
- Cost optimisation of the ERS.

## REFERENCES

- Bakalov, I. (2019). A Contemporary Concept in Troubleshooting and Fixing Malfunctions Using an Engine Room Simulator in Augmented Reality Environment. *Universal Journal of Mechanical Engineering*, 7(2), 33-36. 10.13189/ujme.2019.070201
- Bates, A. W. (2015). *Teaching in a Digital Age*. Tony Bates Associates Ltd.
- Brace, I. (2013). *Questionnaire Design (Third edition. ed.)*. Kogan Page.
- Campbell, D. T., & Fiske, D. W. (1959). Convergent and discriminant validation by the multitrait-multimethod matrix. *Psychological Bulletin*, 81-105.
- Christensen, L., Johnson, R., & Turner, L. (2020). *Research methods, design, and analysis (13th ed.)*. Pearson Education Inc.
- Christians, C. G., & Carey, J. W. (1989). The Logic and Aims of Qualitative Research. *Research Methods in Mass Communication* (pp. 354-374). Prentice-Hall.
- Cicek, K. (2017). A practical training assessment methodology for Engine Room Simulator trainings
- Creswell, J. W. (2013). *Qualitative inquiry & research design*. SAGE.
- Dawson, C. (2006). *A practical guide to research methods (2nd ed. ed.)*. How To Books.
- DNV-GL. (2020). Certification of maritime simulator systems. <https://www.dnvgl.com/services/certification-of-maritime-simulator-systems-2862>
- Ghauri, P. N., & Grønhaug, K. (2005). *Research methods in business studies (3. ed. ed.)*. Prentice Hall/Financial Times.
- International Maritime Organization. (2017a). Model course 2.07. Engine-Room simulator (2017th ed.). IMO Publication.
- International Maritime Organization. (2017b). STCW: including 2010 Manila amendments: STCW Convention and STCW Code: International Convention on Standards of Training, Certification and Watchkeeping for Seafarers (2017 Edition. ed.). IMO Publication.
- International Maritime Organization. (n.d.). Brief history of IMO. <http://www.imo.org/en/About/HistoryOfIMO/Pages/Default.aspx>
- Jensen, O., Flores, A., Corman, V., Canals, M. L., Lucas, D., Denisenko, I., Lucero-Prisno, D., Secher, A., Andersen, G., Jørgensen, M., Pujol, H., Cohen, G., & Gyntelberg, F. (2022). Screening for type 2 diabetes and hypertension in seafarers' medical examinations. *International Maritime Health*, 73, 64-72. 10.5603/IMH.2022.0010
- Kluj, S. (2012). ICERS' Impact on Marine Engineering Training. [www.drkluj.com](http://drkluj.com). [http://drkluj.com/wp-content/uploads/2013/12/ICERS11\\_Kluj\\_Paper.pdf](http://drkluj.com/wp-content/uploads/2013/12/ICERS11_Kluj_Paper.pdf)
- Laskowski, R., Chybowski, L., & Gawdzińska, K. (2015a). An Engine Room Simulator as a Tool for Environmental Education of Marine Engineers. (pp. 311-322)10.1007/978-3-319-16528-8\_29
- Laskowski, R., Chybowski, L., & Gawdzińska, K. (2015b). An Engine Room Simulator as a Tool for Environmental Education of Marine Engineers. (pp. 311-322)10.1007/978-3-319-16528-8\_29

- Lovren, V. O., & Popović, K. (2018). Lifelong Learning for Sustainable Development-Is Adult Education Left Behind? In W. Leal Filho, M. Mifsud & P. Pace (Eds.), *Handbook of Lifelong Learning for Sustainable Development* (pp. 1-17). Springer International Publishing.
- Malaysia Marine Department. (2021). MSN 13/2021: Issuance Requirements of Certificate of Competency and Approved Seatime. Malaysia Marine Department. Retrieved February 16, 2023, from <https://www.marine.gov.my/jlm/admin/assets/uploads/files/notis/f2f57-msn132021.pdf>
- Mallam, S. C., Nazir, S., & Renganayagalu, S. K. (2019). Rethinking Maritime Education, Training, and Operations in the Digital Era: Applications for Emerging Immersive Technologies. *Journal of Marine Science and Engineering*, 7(12), 428. 10.3390/jmse7120428
- Milić-Beran, I., Milošević, D., & Šekularac-Ivošević, S. (2021). Teacher of the future in maritime education and training. *Knowledge International Journal*, 46, 119-125.
- Mukherjee, P. K., & Brownrigg, M. (2013). *Farthing on International Shipping*. Springer.
- Sellberg, C., & Viktorelius, M. (2020). From Technical and Non-technical Skills to Hybrid Minds: Reconceptualizing Cognition and Learning in Semi-automated Environments. Paper presented at the *Advances in Human Factors and Ergonomics 2020*;
- Stetsenko, M., & Stetsenko, P. (2019). Enhancing the effectiveness of engine room simulator training with application of augmented reality technology. Paper presented at the *ICERS13 - International Conference on Engine Room Simulators*,
- Yoga, P. (2018). *Curriculum Design*. Educreation Publishing.
- Zaini, Z. (2020). The effectiveness of engine room simulator (ERS) as a learning tool in maritime education and training (MET) (Master of Science). [https://commons.wmu.se/cgi/viewcontent.cgi?article=2390&context=all\\_dissertations](https://commons.wmu.se/cgi/viewcontent.cgi?article=2390&context=all_dissertations)
- Zincir, B., Dere, C., & Deniz, C. (2017). Scenario-based assessment method for Engine Room Simulator courses

**CONSUMER PERCEPTION OF HALAL LOGISTICS PRACTICES IN MALAYSIA:  
A CONCEPTUAL REVIEW**

Shahidah Binti Ahmad Suhaimi\*, Nadia Harnisa Binti Abdul Rahman, Zulkarnian Binti Ahmad, Chua Kim Muar, Ramesh Babu Amathalai, Nur Zulaikha Binti Samsudin, Aisyah Binti Othman, Ravinjit Singh A/L Pritam Singh

Shahidah.suhaimi@alam.edu.my\*, nadia.harnisa@alam.edu.my,  
zulkarnian.ahmad@alam.edu.my, chuakim@alam.edu.my,  
rameshb.amathalai@alam.edu.my, aisyah.othman@alam.edu.my,  
ravinjit.singh@alam.edu.my

Corresponding author\*

*Lecturer, Faculty of Business & Management, Akademi Laut Malaysia, BT 30 Kg Tg Dahan,  
78200 Kuala Sungai Baru Melaka, Malaysia*

**ABSTRACT**

The market for halal logistics services is expanding. Halal sector-driven diversification of halal goods and services from the standpoints of producers and customers is a recent development. The increasing demands of Muslim consumers, particularly for food and beverages, have expanded the potential for halal logistics services. The perspective of consumers, as well as Logistics Service Providers, can benefit from halal logistics activity. Indirectly, the expanding Muslim population worldwide is the reason for the current spike in demand for halal goods. Customers choose the goods or services to purchase based on whether they will meet their known demands. Marketing initiatives, individual experiences, and societal and cultural influences are just a few examples of the many variables that might affect consumer perception. Hence, the objective of this study is to present a conceptual conclusion regarding how consumers perceive halal logistics in Malaysia. The finding shows that Muslim consumers in Malaysia look for the halal label, which denotes that the product has been approved by the Malaysian religious authority. Customers in Malaysia, therefore, favour halal logistics suppliers with sufficient compliance-based documentation in place as a preventative measure to avoid any issue or disagreement.

**ARTICLE INFO**

*Keywords:  
Consumer,  
Perception,  
Halal,  
Logistics,  
Malaysia*

## **1.0 INTRODUCTION**

According to Bruil (2010), halal refers to things or conduct that are allowed or allowed by *Syariah*. The term "halal" is used to refer to food in any form during trade or commerce as a component of trading or as part of the trading component of the food in question (Talib and Hamid, 2014). The term "halal," or any other term that might be used to denote or might be interpreted as indicating that food is acceptable and allowed to be consumed by Muslims and is permitted for the referred food to be consumed in their faith, was guaranteed to refer to Muslim food, halal food, or any other term.

Why does halal logistics is a concern to Malaysian consumers? Most consumers in Malaysia are Muslims (Fernando et al., 2023). Hence, consumer demands in Malaysia may lead to the evolution of the halal logistics industry to ensure that every food item comes from an actual manifestation of Islamic principles.

Halal logistics is defined as the processes in the movement and distribution of goods and services in the supply chain according to the *Syariah* principles (Tieman, 2013). According to Al-Kahtani et al. (2017), halal logistics refers to not only the process of guaranteeing that goods are transported and delivered in accordance with Islamic law but also principles such as avoiding the use of prohibited substances, ensuring the humane treatment of animals, and adhering to ethical business practices. All the processes are essential for Muslims in ensuring that the products they consume are permissible according to Islam.

Halal logistics practices include six (6) key components that guarantee the physical separation of halal cargo from non-halal cargo at each point of contact with the consumer, from the transportation ports to the final destination. This includes the activities associated with warehousing (Tieman et al., 2013; Zailani et al., 2017; Karia and Asaari, 2016).

Based on the *Syariah* law and the Muslim population in Malaysia, the latest study of halal logistics is in demand. Therefore, the purpose of this paper is to provide a conceptual finding on the consumer perception of halal logistics.

## **2.0 CONSUMER PERCEPTION OF HALAL LOGISTICS**

### **2.1 Consumer Perception**

Customers decide whether products or services to buy depending on whether they will satisfy their known needs (Agyekum et al., 2015). According to the consumer's assessment of the product's suitability to fulfil that demand, they will decide whether to buy it (Agyekum et al., 2015).

According to a study by Stampa et al., (2020), consumer perception can be influenced by several factors, including marketing activities, personal experiences, and social and cultural factors. The author suggests that marketers should aim to create positive consumer perceptions by focusing on product quality, brand image, customer service, location and type of product; this must be taken into consideration in marketing plans. Other than that, advertising, reviews, social media, public relations, personal experience, and others can also affect consumer perception. All these factors can lead to the consumers' actions in selecting food products (Ruslan et al., 2018).

According to Majid et al (2021), perception refers to a consumer's view or belief in a product or service. Nowadays, customers strongly feel that consuming halal products signifies that they are leading a healthy lifestyle. Furthermore, consuming or eating halal items is seen as a religious obligation for Muslim brothers and sisters (Mathew, 2014).



## 2.2 Halal Logistics Performance

In halal companies, the halal concept extends beyond the manufacturing and packaging stages and calls for stringent controls all the way through the transportation chain, all the way up until the product is finally delivered to the customer (Zailani et al., 2017, as cited in Fernando et al., 2023). Leaving a product unattended after it has been produced and distributed runs the risk of it losing its halal status because there is a very high chance that it may become contaminated while being transported or stored, and this issue highlights the value of the Halal Supply Chain (HSC) procedures (Fernando et al., 2023).

According to Fernando et al., 2023, quality, time, cost, and flexibility may be utilised to categorise the performance of halal logistics. To ensure the halal concept is applied, halal certifiers must monitor all halal logistics activities, such as *Jabatan Kemajuan Islam Malaysia* (JAKIM) (Masudin et al., 2018).

In encouraging the logistics industry to perform halal logistics, halal certification can be used by Logistics Service Providers (LSPs) as a strategic differentiator to stand out in a market and as guidance to enhance logistic performance (Fernando et al., 2023). Hence, customers may feel more confident in the transparency of halal items if they can see the physical movement of those things. Halal logistics can therefore affect the performance of logistics as a whole (Fernando et al., 2023). Halal logistics activities can be valuable not only to the LSPs but also to the consumer perception.

Logistics suppliers must have strong logistical performance to increase customer happiness and loyalty (Masudin et al., 2018). According to Tieman and Ghazali (2013), Malaysian stores feature non-halal areas for non-halal meat to demonstrate to the buyer that one product has gone through halal logistics. Malaysia has authorised halal warehouses and certified halal transit, and Northport Malaysia has halal logistics policies in effect (Tieman and Ghazali, 2013).

## 2.3 Demands on Halal Logistics

The recent surge in demand for halal products is indirectly due to the growing Muslim population around the world. The number of Muslims in the world is anticipated to rise from 1.6 billion in 2010 to 2.2 billion in 2030, a rise of roughly 35 per cent (Jaafar et al., 2011).

According to Kamaruddin et al (2012), customers in the consumer and industrial sectors have higher expectations for more precise criteria to establish the requirements for halal compliance within the logistic sector is one of the spillover effects of the demand for halal logistics. If people are demanding something, they are willing to pay the cost of the product and services. Besides, according to Statista, a 2020 survey found that 63.5% of all Malaysians identify as Muslims, making the halal market a crucial industry for the country's commerce and economic growth (Santiago, 2022).

In a study by Tieman et al (2013) (as cited in Talib and Wahab, 2021), consumers are willing to pay more for halal logistical services. Consumer demands also could eventually spur the development of the Halal logistics sector, ensuring that every food product originates from a genuine application of Islamic principles (Fernando et al., 2023). It is also seen that the halal business is propelled not only by financial incentives but also by the necessity to meet local food demand (Talib and Wahab, 2021).

In the Market Analysis Report (2020) in 2019, the size of the global halal logistics market was estimated at USD 286.96 billion. From 2020 to 2027, it is anticipated to rise at a compound annual growth rate (CAGR) of 8.4% (figure 1). The rise in global halal food trade is in part due

to the rising Muslim population, which increased consumer expenditure on halal goods. Due to superior educational and employment prospects, as well as a much younger population than any other religion in the world, Muslim consumers' spending power has expanded significantly over the past several years.

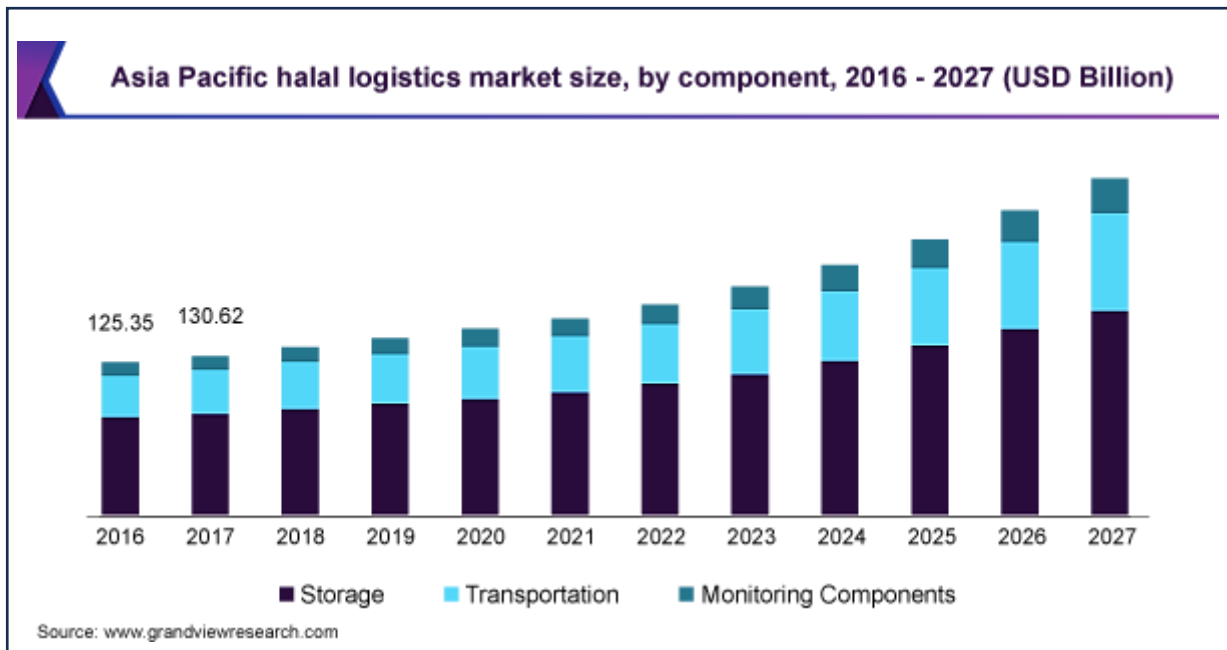

Figure 1: Asia Pacific Halal Logistics Market Size 2016 to 2027

### 3.0 FINDINGS AND DISCUSSION

A strategy often used by firms is to improve logistics operations to maximise profits while preserving high levels of customer satisfaction. The halal logistics sector has experienced a notable expansion in this environment (Doğaner and Fidan, 2023). Customer perception has a significant role in the effectiveness of halal logistics since it investigates the variables that affect customer willingness to spend. The degree of customer confidence in halal certification was also examined by Latif et al. (2014). The findings showed that misleading information about the halal logo or certification may cause a significant loss of confidence. The perception of the consumer, however, goes beyond just halal items and encompasses the entire halal process, from the beginning of production through delivery at the destination, including all logistics activities (Khan et al., 2019). The same study also indicated that customer willingness to pay for halal logistics is positively and substantially associated with concern over halal.

The halal integrity of the halal products will suffer if halal criteria are not followed. When halal items are given to end customers, the risk of contamination rises due to the halal supply chain's subpar performance, which may compromise halal purity (Ruangsriroj and Suvittawat, 2022). Concerns regarding a few unethical commercial practices that degrade the quality of services offered by Logistics Service Providers (LSPs) of Halal items have been raised by customers, logisticians, and related sectors (Haleem et al., 2021). The study also discovered that customers' behaviour is directly impacted by concerns about halal by increased efforts to uphold Islamic principles. This illustrates how crucial halal assurance services are for customers. Governments must therefore increase users' understanding of Halal through various sources. The increased

demand for halal goods on a global scale compels logistics service providers to incorporate halal logistics.

On the other hand, due to high initial costs and a lack of resources to implement halal logistics, many logistics companies are unable to provide halal logistics services and are unable to gain the certification necessary to do so. Consequently, customer satisfaction suffers significantly because of the inadequate resource capacity of halal logistics services (Karia, 2022). It has also been amply demonstrated that consumers' perceptions of halal logistics and willingness to pay for them are closely related (Majid et al., 2021). Referring to the same study's findings, non-Muslims who were knowledgeable about halal and had a favourable opinion of halal logistics may be willing to pay for it.

In Malaysia, Muslim buyers seek the halal label, which indicates that the product has been certified by the Malaysian religious authority. The Department of Islamic Development Malaysia (JAKIM) is the authority in charge of halal assurance in Malaysia (Selim et al., 2022). Malaysia's halal certification is internationally recognised as a commercial setup for the halal products market. Muslim halal food customers, who make up the majority of Malaysians, have demonstrated a better comprehension of the halal concept. Furthermore, a study by Mohd et al (2022) revealed variances in the level of separation between Muslim and non-Muslim consumers.

In comparison to non-Muslim consumers, Muslim consumers are more willing to pay more. Therefore, halal logistics is critical, particularly for Muslim consumers in Malaysia, where tight regulations are required to ensure that halal is assured from beginning to end. Previous research (Zainuddin et al., 2023) indicates that customers in Malaysia prefer halal logistics providers with adequate compliance-based paperwork in place as a preventive strategy to avoid any problem or conflict with regulatory agencies and customers.

#### **4.0 CONCLUSIONS**

The halal business has grown in recent years because of the rising demand for halal products from both Muslim and non-Muslim consumers and the understanding that halal is a global concept shared by both Muslim and non-Muslim cultures. According to this study, Malaysian consumers prefer Halal items that use Halal logistics practices. It is consistent with a prior study, which revealed that Muslims are willing to pay for halal logistics due to demand, a favourable perception of halal logistics, and worries regarding halal components (Majid et al., 2021). Consumers today are interested not just in the production process but also in the complete supply chain activities, including halal slaughter.

The study's findings will give light on policymakers and logistics providers to develop policies and processes to improve consumer satisfaction in Halal logistics. Additionally, the government must actively promote by organising events, campaigns, and other feasible means to inform customers about halal, Halal Supply Chain (HSC), and halal logistics. However, this research can be expanded by collecting primary data from consumers and also logistics provider in order to get more insights on their perceptions towards Halal Logistics.

## REFERENCES

- Agyekum, C. K., Haifeng, H., Agyeiwaa, A., Agyekum, C. K., Haifeng, H., & Agyeiwaa, A. (2015). Consumer Perception of Product Quality. *Microeconomics and Macroeconomics*, 3(2), 25-29.
- Al-Kahtani, H. A., Ahmed, M. A., Abou-Arab, A. A., & Hayat, K. (2017). Identification of Lard in Vegetable Oil Binary Mixtures and Commercial Food Products by FTIR. *Quality Assurance and Safety of Crops & Foods*, 9(1), 11-22.
- Bruil, R. R. (2010). Halal Logistics and the Impact of Consumer Perceptions (Master's thesis, University of Twente).
- Doğaner, B., & Fidan, Y. (2023). Halal Logistics as the Basis of Halal and Healthy Food and Its Potential Contribution to The Economy. *Journal of Emerging Economies and Islamic Research*, 11(1), 1-14.
- Fernando, Y., Wahyuni-TD, I.S., Zainul Abideen, A. & Mergeresa, F. (2023). "Traceability Technology, Halal Logistics Brand and Logistics Performance: Religious Beliefs and Beyond", *Journal of Islamic Marketing*, Vol. 14 No. 4, pp. 1007-1031. <https://doi.org/10.1108/JIMA-06-2020-0183>
- Haleem, A., Khan, M. I., & Khan, S. (2021). Understanding the Adoption of Halal Logistics through Critical Success Factors and Stakeholder Objectives. *Logistics*, 5(2), 38.
- Jaafar, Harlina Suzana, Intan Rohani Endut, Nasruddin Faisol, & Emi Normalina Omar (2011). "Innovation in Logistics Services–Halal Logistics." 844-851.
- Kamaruddin, R., Ibrahım, H., & Shabudin, A. (2012). Willingness to Pay for Halal Logistics: the Lifestyle Choice. *Procedia-Social and Behavioral Sciences*, 50, 722-729.
- Karia, N. (2022). Halal Logistics: Practices, Integration and Performance of Logistics Service Providers. *Journal of Islamic Marketing*, 13(1), 100-118.
- Karia, N., & Asaari, M. H. A. H. (2016). Halal Business and Sustainability: Strategies, Resources and Capabilities of Halal Third-Party Logistics (3PLs). *Progress in Industrial Ecology, an International Journal*, 10(2-3), 286-300.
- Khan, M., Najmi, A., Ahmed, W., & Aman, A. (2019). The Role of Consumer Willingness to Pay for Halal Certification in Pakistan. *Journal of Islamic Marketing*, 10(4), 1230-1244.
- Latif, I. A., Mohamed, Z., Sharifuddin, J., Abdullah, A. M., & Ismail, M. M. (2014). A Comparative Analysis of Global Halal Certification Requirements. *Journal of Food Products Marketing*, 20(sup1), 85-101.
- Majid, D. K. Z.A, Abdul Hanan, S., & Hassan, H. (2021). A Mediator of Consumers' Willingness to Pay for Halal Logistics. *British Food Journal*, 123(3), 910-925.
- Market Analysis Report (2020). *Halal Logistics Market Size | Industry Report, 2020-2027*. <https://www.grandviewresearch.com/industry-analysis/halal-logistics-market>
- Masudin, I., Fernanda, F. W., & Widayat, W. (2018). Halal Logistics Performance and Customer Loyalty: From the Literature Review to A Conceptual Framework. *International Journal of Technology*, 9(5), 1072-1084.
- Mathew, V. N. (2014). Acceptance on halal food among non-Muslim consumers. *Procedia-Social and Behavioral Sciences*, 121, 262-271.
- Mohd Faizal, M. D. H., Affendi, A. I. & Omain, S. Z. (2022). Consumers' Perception Towards Halal Logistic Concept in Malaysia. *International Journal of Advanced Technology*

Management and Entrepreneurship, 4(1). Retrieved from <http://amcs-press.com/index.php/ijatme/article/view/244>

- Ruangsiroj, T., & Suvittawat, A. (2022). The Factors Influencing Value Creation of Halal Logistics Service during Crisis: A Case Study of Halal Logistics Service Providers in Thailand. *Asian Journal of Business Research* Volume, 12(2).
- Ruslan, A. A. A., Kamarulzaman, N. H., & Sanny, M. (2018). Muslim Consumers' Awareness and Perception of Halal Food Fraud. *International Food Research Journal*, 25, S87-S96.
- Santiago, A. (2022). An Overview of Malaysia's Halal Industry. Growing the Halal Market in Malaysia. <https://ycpsolidiance.com/article/overview-halal-market-malaysia>
- Selim, N. I. I. B., Zailani, S., Aziz, A. A., & Rahman, M. K. (2022). Halal Logistic Services, Trust and Satisfaction amongst Malaysian 3PL Service Providers. *Journal of Islamic Marketing*, 13(1), 81-99.
- Stampa, E., Schipmann-Schwarze, C., & Hamm, U. (2020). Consumer Perceptions, Preferences, and Behavior Regarding Pasture-Raised Livestock Products: A Review. *Food Quality and Preference*, 82, 103872.
- Talib, M. S. A. & Wahab, S. N. (2021). Halal Logistics in a Rentier State: An Observation. *Modern Supply Chain Research and Applications*, 3(2), 155-170.
- Talib, M. S.A., & Hamid, A.B.A (2014). Halal Logistics in Malaysia: a SWOT Analysis. *Journal of Islamic Marketing*, 5(3), 322-343.
- Tieman, M. (2013). Establishing the Principles in Halal Logistics. *Journal of Emerging Economies and Islamic Research*, 1(1), 19-31.
- Tieman, M., & Che Ghazali, M. (2013). Principles in Halal Purchasing. *Journal of Islamic Marketing*, 4(3), 281-293.
- Tieman, M., Che Ghazali, M., & Van Der Vorst, J. G. (2013). Consumer Perception on Halal Meat Logistics. *British Food Journal*, 115(8), 1112-1129.
- Zailani, S., Iranmanesh, M., Aziz, A. A., & Kanapathy, K. (2017). Halal Logistics Opportunities and Challenges. *Journal of Islamic Marketing*, 8(1), 127-139.
- Zainuddin, Anizah Zainuddin Anizah, Sarah Irdina Ridzwan & Sarah Batrisyia Ridzwan. (2023). "Role of Trust and Relationship Enhance Retail Halal Supply Chain Practices and Customers' Perception Of Halal Compliance." *International Journal of Social Science Research* 5, no. 1: 122-135.